

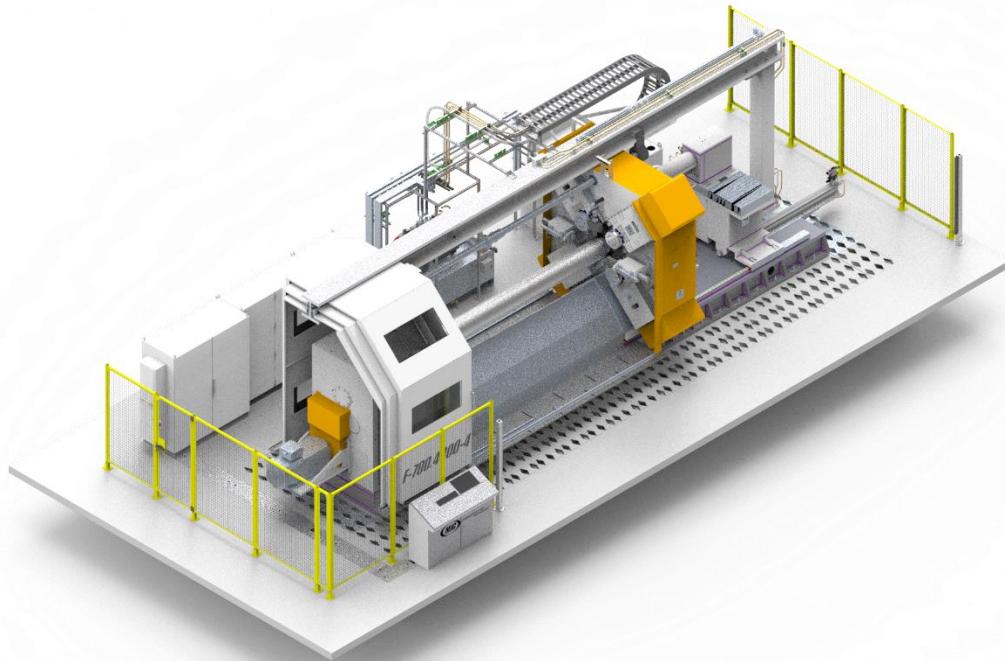

**ENGINEERING AND
TECHNOLOGY, INC.**

Machine User Manual

F700.4000 Flow Former



15401 Assembly Lane, Huntington Beach, CA 92649

Phone: (714) 890-0618

Fax: (714) 895-3561

www.mjcengineering.com

This page intentionally left blank



Table of Contents

1. Foreword	5
2. Safety.....	6
2.1 Safe and Intended Use of the Machine	6
2.2 Organizational Measures	7
2.3 Staff Assignment and Qualification.....	7
2.4 Initial Safety Procedures	8
2.5 Warning Labels	9
3. Transportation & Installation	11
3.1 Machine Packaging	11
3.2 Lifting & Transporting	11
3.3 Intermediate Storing	12
3.4 Installation	12
3.5 Commissioning the Machine.....	12
4. Technical Specifications	14
5. Machine Information	15
5.1 Structure of the Machine	15
5.2 Axis Directions	16
5.3 Basic Components of the Machine	17
5.3.1 Machine Bed (-010-).....	17
5.3.2 Headstock (-020-)	17
5.3.3 Tailstock (-030-).....	18
5.3.4 Slide Assemblies (-040-).....	19
5.3.5 Spindle Motor (-080-).....	21
5.3.6 Door Assembly (-120-).....	26
5.3.7 Operator Controls or HMI (-850-)	27
5.3.8 Green Hydraulic Power Unit (-950-).....	32
6. Included Software	33
6.1 Input/Output Screen.....	33
6.2 SpinCAD 4.0	34
7. Maintenance & Inspection	35
7.1 General Information.....	35
7.2 List of Maintenance and Inspections Items	36
7.3 Machine Required Oil and Lubrication	37
7.3.1 Oil and Lubrication Schedule	37



7.3.2 Machine Oil and Lubrication Locations	38
7.4 Hydraulic Oil Change	44
7.4.1 Maintenance of the Oil Filter	44
8. External Manuals	46
Siemens Manuals	46
9. SpinCAD Manuals.....	46
10. Spare Parts List	46
11. Schematics and Drawings	46
12. Terms and Conditions.....	46

1. Foreword

The MJC Engineering and Technology (MJC) terms and conditions are at the end of this document.

The MJC F700.4000 Flow Former is a 6 axis, 2 AC vector drive, computer numerical control (CNC) machine used for the spinning and shaping of metal material. The included machine software package is the best and latest MJC has to offer.

The machine is equipped with a “Siemens Sinumerik One” system. This is the latest Siemens digital control for multi-axes controls. All electrical components used are certified and industry standard, which makes service and support more widely available.



2. Safety

This manual contains instructions for machine operation and safety.

MJC requires that this manual will always be available in an easy-to-access, dry, and unlocked location near the machine.

MJC requires the following personnel to read, understand, and to actively exercise the safety procedures in this document, which include but is not limited to: machine operators, setup operators, maintenance personnel, and anyone performing any action in or around the machine.

If there are any questions or comments, do not hesitate to directly contact MJC Engineering and Technology.

Use in conjunction with OSHA or local regulations or law.

This manual is subject to technical changes contrary to the descriptions and data in this manual.

2.1 Safe and Intended Use of the Machine

- The machine was designed with the latest technology, safety devices, safety regulations and procedures that are appropriate for operating heavy industrial equipment.
- The machine is intended to be used in perfect condition, with all safety devices active, and while following all safety regulations supplied by OSHA, local regulations, and the regulations in this manual.
- The safety devices include but are not limited to: emergency shut-off buttons (E-Stop buttons), machine status lights, audible alarms, dead-man switches, fences, doors, door locks, warning labels, sensors, safety scanners, and automatic shut-off functions in the machine's code and software.
- The machine is intended to be used with the aforementioned "code and software" (software) that is approved by MJC. This includes but is not limited to the software in the following conditions: the original unaltered software initially delivered with the machine, any updates carried out by MJC employees, and updates carried out by non-MJC employees with explicit permission from MJC.
- The machine is intended to be used to produce high quality parts within the specifications laid out in the contract between the customer and MJC, and within the designed load or forces that include but are not limited to the: mechanical, hydraulic, and electrical systems.
- The machine is intended to be used only when all "MJC approved maintenance tasks" are complete, and this includes individual maintenance procedures, and maintenance schedules as a whole. They are detailed in this manual, and can include other maintenance tasks as long as they don't interfere.
- MJC recommends to follow the maintenance schedule, this can prevent emergency repairs, or reactive maintenance, and extend the life of the equipment.
- Any other use or any use exceeding its purpose shall be considered as not intended.
- Unsafe operation in or around the machine, or machine malfunctions, may result in the loss of life or property. The user is responsible to read, understand and follow these safety instructions.



2.2 Organizational Measures

- Always store this manual in a dry and easy-to-access and unlocked location near the machine.
- Always follow local regulations and laws that apply to each facility or factory. For example, but not limited to: regulations that prevent accidents, or environmental laws that mandate how to dispose of oil or other hazardous substances.
- User should include in the operating instructions any regulations including supervisory duties and duties of notification concerning company policies, such as work organization, operating sequences, staff assigned, etc.
- It is mandatory that staff who use or maintain the machine have read the manual, specifically the safety instructions before getting near the machine. This especially applies to personnel working near the machine during set-up, load/unload material, maintenance tasks, etc.
- Frequently check the safety and consciousness of any personnel near the machine.
- Machine operators should operate the machine with long hair tied up, and loose clothing or jewelry secured, to decrease the risk of the operator of being caught in the machinery.
- Use personal protective gear at all times, i.e., safety glasses, hearing protection, steel-toe boots, gloves and anything else required by local regulation.



- Observe all safety and hazard labels and signs on the machine.
- Any irregularities with the operation of the machine are to be reported immediately to the proper level of supervision dictated.
- Do not carry out any modification or retrofits to the machine involving its safety without prior consultation with MJC.
- MJC recommends a safety fence around the perimeter of the machine, or any machine controlling device or computer, to ensure there is no unauthorized use or tampering with the machine.
- Do not make any program changes (software) on the PLC control system without prior consultation with MJC.
- Observe periods for repeating checks/inspections as regulated or indicated in the operating manual.
- For the proper execution of maintenance works, the proper workshop equipment is essential.

2.3 Staff Assignment and Qualification

- Only reliable personnel may carry out work in or near the machine. Please observe the minimum age as regulated by law.
- Only assign trained staff with clear roles or responsibilities. These clear roles or responsibilities include but are not limited to: machine operators, set-up personnel, maintenance crew, service technicians, supervisors, and a well-documented process to communicate issues with the machine to the appropriate levels of authority within the company.
- MJC recommends staff to be trained under the constant supervision of an experienced personnel.

2.4 Initial Safety Procedures

- Refrain from any working methods that jeopardize safety of the operator or those around!
- Check the machine at least once per shift for external damage and defects. Immediately notify the responsible department or staff about any changes that have occurred, including the operational behavior. If the responsible department or staff determine that the machine needs to be stopped or fixed, then stop the machine, and follow lockout/tagout procedures.
- In the case of a malfunction, immediately stop the machine and follow lockout/tagout procedures.



- Before start-up of the machine, make sure that no personnel are exposed to hazards by starting the machine.
- Document any procedures that include but are not limited to: start-up, shut down, load or unload, maintenance, inspection, tool changes, adjustments made to the position or offsets of any machine component, and any replacement of parts or assemblies.
- Inform operators before any maintenance begins.
- For any work involving: operation, production change-over, adjustment of the machine or its safety related systems, inspection, maintenance or repair, then please observe switch-on and switch-off operating instructions and the service specific details of the work order.
- In the aforementioned work orders, fence off the service area as far as possible, and follow all safety regulations to raise visibility of operators, maintenance personnel, equipment, and fencing.
- If the machine has been switched-off completely or partially for service and repair work, then the machine must be protected against accidental start-up. Follow lockout/tagout procedures.



- Carefully attach single components and larger assemblies to the proper lifting gear during replacement and protect them against hazards. Only use suitable and appropriately rated lifting gear and load suspension equipment with sufficient load carrying capacity.
- For maintenance tasks that involve components lifted above head height, it is mandatory to use proper ascent equipment and working platforms.
- For maintenance tasks that involve personnel above head height, it is mandatory to use proper man-baskets, wire/rope slings.



- Clean the machine, specifically all connections and fittings from oil, fuel, debris or cleaning agents before starting any maintenance/repair work. Do not use aggressive cleaning agents.
- Always retighten down any screw connection or fasteners that were loosened during maintenance or repair work.
- If dismantling of safety equipment is required during setup, maintenance and repair, mounting and verification of the safety equipment has to be re-implemented immediately after termination of maintenance and repair works.

2.5 Warning Labels



Electrocutation Hazard

Death by electric shock can occur.
Lock Out, Tag Out before servicing.



Rotating Parts Hazard

Rotating parts can entangle and trap. Severe injury can occur. Always secure loose articles of clothing and long hair.



Projectile Hazard

Inadequately clamped or improperly heated parts can be thrown with deadly force.



Eye and Ear Hazard

Flying debris into unprotected eyes can damage one's eye sight.

Noise levels can also exceed 50 dBA.

Always wear safety glasses and ear plugs when operating the machine.



Projectile Hazard

The safety door may not stop all projectiles.

Always double check job set-ups and never operate the machine with the door open or guards removed.



Lock Out, Tag Out

Always Lock Out, Tag Out before performing maintenance on the machine.

Electrical

- Work on electrical equipment is inherently dangerous and should only be carried out by a qualified electrical technician or by staff under the supervision of a qualified electrical technician.



- Before any machine components can be inspected, maintained, or repaired, they must be powered off. Then confirm that it is voltage-free. Then ground or short these components, and insulate any adjacent components under voltage.



- Use only original fuses with the appropriate current ratings. In the event of a malfunction in the energy supply, switch the machine off immediately!
- Defects such as loose connections and/or scorched cables have to be removed immediately.
- If work on live components is required, a second person should be present who may activate the emergency shut-off and/or the main switch in an emergency.

Hydraulics & Pneumatics

- Check all hydraulic tubes, hoses, and fittings in regular intervals for leakages. Remove any damaged lines immediately. Any leaking oil present may lead to injuries and/or fires.
- Depressurize machine sections before beginning any maintenance or repair work.
- Only persons with specific knowledge and experience in said fields may carry out work on hydraulic and pneumatic equipment.

Gas, Vapors and Smoke

- High risk of fire or explosion due to use of highly volatile and combustible gases. (i.e. propylene, propane and oxygen)



- Customer to ensure that adequate ventilation is provided due to the high level of combustible gas that is used during machine operation
- Carry out welding, grinding and torch work on machine only when permitted.
- For work in tight spaces, please observe follow local regulations and laws.

3. Transportation & Installation

3.1 Machine Packaging

Protection – The machine must be protected against impact, vibration and outside forces.

Avoid condensation of water, which may result from temperature variations that will cause corrosion.

All the points of suspension and the points of the machine coming into contact with strap/chains have been protected against putting defects into the machines paint.

3.2 Lifting & Transporting



Use only suitable cranes, elevators, forklifts and other means of transport with sufficient lifting and carrying force for lifting and transport the machine parts. Common sense safety rules should be followed at all times. When installing or maintaining machine, and lifting gear is required, ensure only suitable and technically flawless lifting gear and load suspension equipment is used!



DO NOT STAY OR WORK UNDERNEATH LIFTED LOADS!



For mounting components/maintenance above body height, use suitable and proper ascent equipment and working platforms. Do not use machine components as a means for climbing.



The machine should only be lifted at marked lift points. Look for the hook sign. Use machine diagrams on for reference as to where the proper lifting points and the center of gravity of the machine will be. These points are to be used for reference only and should not be relied upon to ensure proper load lifting safety. Please consult with a rigging consultant/contractor.

3.3 Intermediate Storing

If the machine is not immediately assembled after delivery, or will be relocated with MJC approval, then follow the steps in this section.

Steps to safely store the machine:

- The machine must be stored in a dry place, and free of vibrations.
- The machine must also be covered properly to prevent contamination by: dirt, humidity, rust, other weather hazards, and animal infestations.
- The exposed metal on the machine has an initial shipping coating to protect against rust.
- The machine may come with blocks or stoppers that stop components on rails from moving. Please store these blocks or stoppers upon arrival, and use them for storing the machine.
- The storage location should be a reinforced concrete floor. If this is not an option, then a wooden foundation of adequate size may suffice.

3.4 Installation

Final Placement – The final placement of the machine must be approved by MJC, and must include sufficient unobstructed space around the machine that MJC deems necessary.

Floor – The machine must be installed on a solid, level, and steel reinforced concrete floor.

Machine Leveling – Reference Unisorb’s documentation for the installation and leveling of Unisorb products.

Ventilation – Customer is to provide adequate ventilation from any fume, as per local regulations and laws.

3.5 Commissioning the Machine

Step 1: Mechanics

Coolant System – If installed, fill the coolant tank and refer to the oil and lubrication section.

Headstock – Fill the headstock with the oil type and quantity as described in the oil and lubrication section. Confirm the oil level with the sight glass. Also, if there is a gear selector installed, then check that it is in gear to avoid damaging the gear teeth upon start-up.

Step 2: Electrical

Follow all local regulations while doing electrical work, and use proper lock-out-tag-out procedures.

Main Electrical Power – Customer to connect main electrical power from switching cabinet to the machine.

Electrical Components Check – Open the main electrical cabinet and remove any shipping packing or bracing that may have been installed for shipping.

Pay attention to the machine operating voltage and any connected loads on the circuit!



Step 3: Hydraulics

Initial Oil Fill – Fill the hydraulic reservoir with hydraulic oil to the top of the level sight-glass. Use only the hydraulic oil specified in the oil and lubrication section of this manual.

If equipped with water-cooling, open the water supply and test the water flow in and out of the system.

The hydraulic pressure of each valve has been pre-set by the factory and should not be tampered with.

Step 4: Compressed Air

If compressed air is required for machine operation, then connect a line to the machine. The compressed air supply should be of sufficient pressure and volume for proper machine function. The compressed air supply may be filtered or lubricated on the input side. The exhaust side must be removed of any lubrication, and follow the local atmospheric regulations or laws.

Step 5: Cleaning

If the machine has the initial shipping coating, then clean it by wiping down with rags. Do not use compressed air to clean the machine.

Step 6: Turn Power On

- Turn on electrical mains power when safe, then turn on the switch at the electrical cabinet.
- Then wait for the CNC system to boot up to the main screen.
- Ensure that all E-Stop buttons are unlocked or unlatched.
- Press the green “Power On” button on the main control panel. Now the green “Power On” button should be illuminated, but there are a few more steps to get the green “CNC Ready” light to turn on.

Step 7: Check Exhaust Fans

- Check that the exhaust fans rotate on the hydraulic motor and any other blower motor.

Step 8: Check Operation of Pumps and Fluid Levels

- If installed, verify that the coolant reservoir is operational and has enough coolant.
- If installed, verify that the spindle lubrication pump is operational and has enough lubrication.
- If installed, verify that the slide lubrication pump is operational and has enough lubrication.
- If installed, verify that the part spray lube system is operational and has enough lubrication.

Final System Check

Once Steps 1–8 have been verified, then do the final system check:

- Make sure that the GHP’s system pressure is dialed down for the lowest pressure setting.
- Start the hydraulic system with one person ready at an E-Stop button, and have another person walk around the machine to visually inspect for any leaks. Press the E-Stop immediately for any leak, do not operate the machine any further, and notify the responsible party for the leak. Only continue this system check, or machine operation, when the responsible party deems it safe to do so.
- Ensure that there are no obstructions along the expected movement of any axis.
- When ready, increase the hydraulic system pressure to normal operating pressure.
- Reference each axis.
- Move or activate each auxiliary device to confirm functionality, while checking to avoid collisions.
- The machine is now ready for operation.



4. Technical Specifications

Machine Data

• Z Axis stroke:	3945 mm
• Z Axis max force:	350 kN
• Z Axis max speed:	10 mm/sec.
• X Axis stroke:	285 mm
• X Axis max force:	275 kN
• X Axis max speed:	5 mm/sec.
• Tailstock max force:	50 kN
• Tailstock Nose DIN:	A-8
• Green Hydraulic Power Unit:	67 HP (57 KW)
• Spindle AC vector drive motor:	300 HP
• Spindle speed range:	50 – 200 RPM
• Spindle total ratios:	36:1 and 9:1
• Spindle (Mandrel) DIN:	A-15
• Machine weight:	215000 lbs. (97500 kg)

Required Utilities

• CNC amperage @ 380V-50Hz:	323 A
• Spindle amperage @ 380V-50Hz:	380 A

Required Fluids for Operation

• Hydraulic oil in the GHP tank:	200 gallons
• Continuous supply of water for the 2 heat exchangers with these specifications:	
○ Flow of 50 lpm, pressure of 3-30 bar, and a maximum temperature of 25°C	

Required Machine Operating Conditions

• Minimum ambient temperature:	10 ° C
• Maximum ambient temperature:	49 ° C
• Maximum air humidity:	80%

In order to prevent system failure, electrical grounding according to DIN standards must be provided inside the plant to ground all machines, electrical cabinets, etc.



5. Machine Information

5.1 Structure of the Machine

- Headstock
- Tailstock
- Main forming slide
- Spindle
- Drain system
- Sliding doors
- Crane
- Green Hydraulic Power Unit (GHP)
- Operators Panel - Human Machine Interface (H.M.I.)

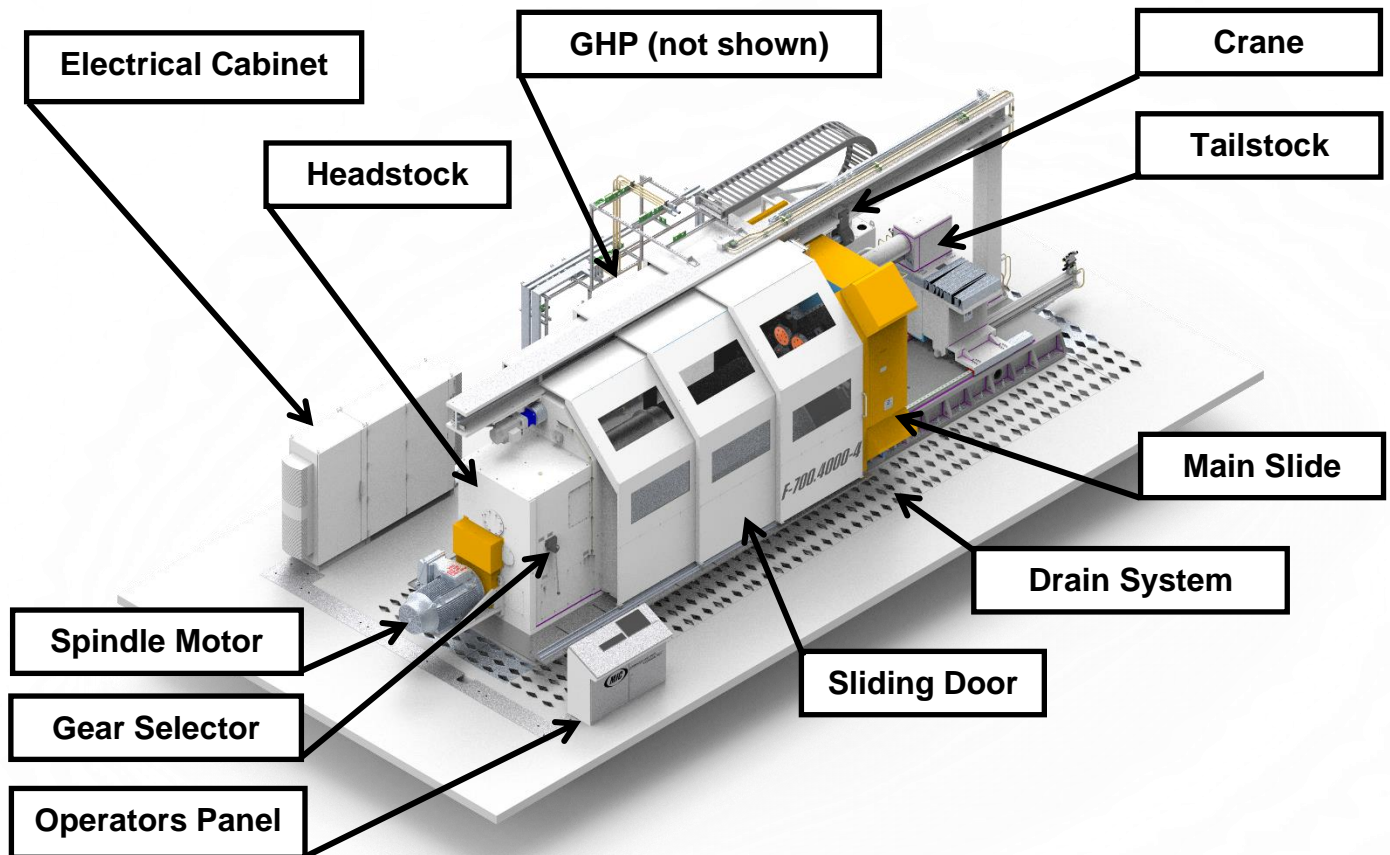

5.2 Axis Directions

MJC has setup the machine axis directions as shown below.

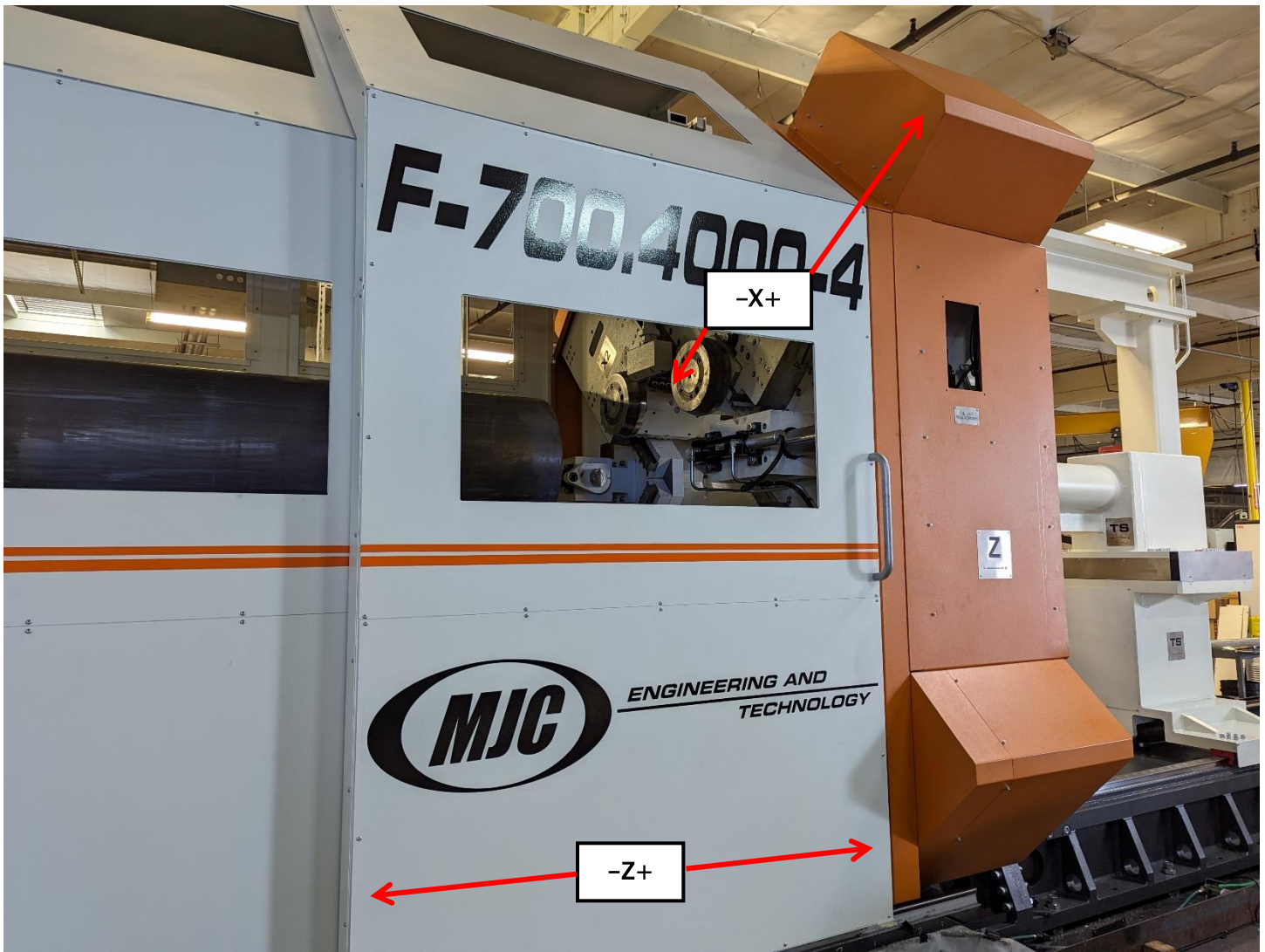

5.3 Basic Components of the Machine

Each section contains the assembly number in parenthesis, for easy reference to the mechanical drawings.

5.3.1 Machine Bed (-010-)

The machine bed is made of high strength, heat treated steel with exceptional rigidity. It is the foundation of the machine and is designed to withstand the forces which occur during a part's formation.

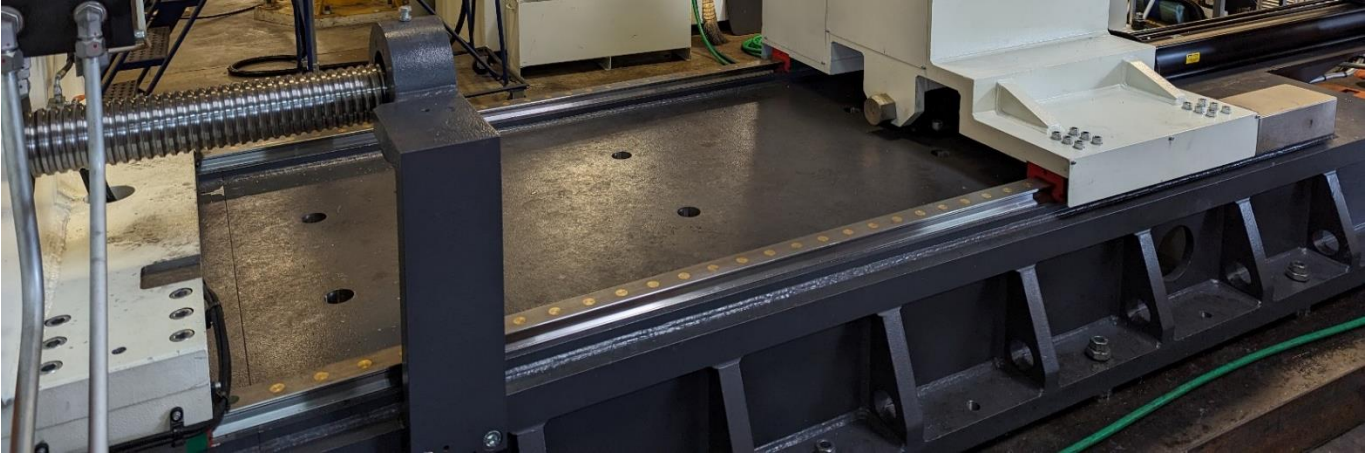

5.3.2 Headstock (-020-)

The headstock is the housing that contains the belt driven rotary assembly called the spindle. The part is spun and pushed by the four rollers, which is also known as metal flow forming. In this document the words “headstock” and “spindle” are used interchangeably.



5.3.3 Tailstock (-030-)

The tailstock holds the part against the mandrel during “normal flow forming” operations, and is not required for “reverse flow forming” operations.

This tailstock is also equipped with a hydraulic system to laterally move the tailstock out of the way for loading and unloading of parts, which is called “TS Shift” on buttons and control screens.



5.3.4 Slide Assemblies (-040-)

The main forming slide is responsible for the flow forming of the part.

It consists of four hydraulic axis, and two electric driven ball screws, a coolant delivery nozzle, and two strippers that engage a stripper ring to pull the part off the mandrel.

Z Slide Assembly

The two electric driven ball screws have axis names Z1 and Z2.

The Z1 ball screw is the upper one.

The Z2 ball screw is the lower one, that is normally protected by the way cover.

The negative direction is toward the headstock, and the positive direction is toward the tailstock.

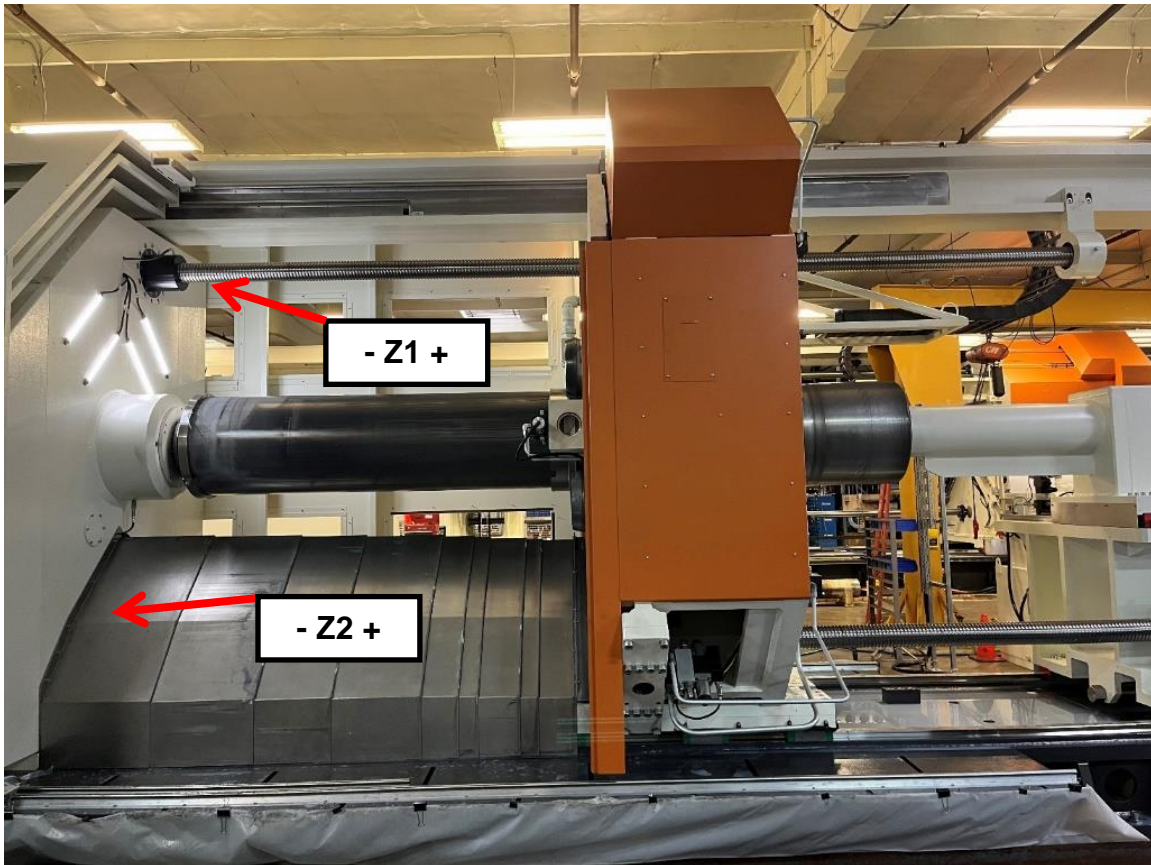

X Slide Assembly

The four hydraulic driven axis are X1-X4, where X1 is at the top right if you are standing in front of the HMI. The axis number goes up in the counter-clockwise direction.

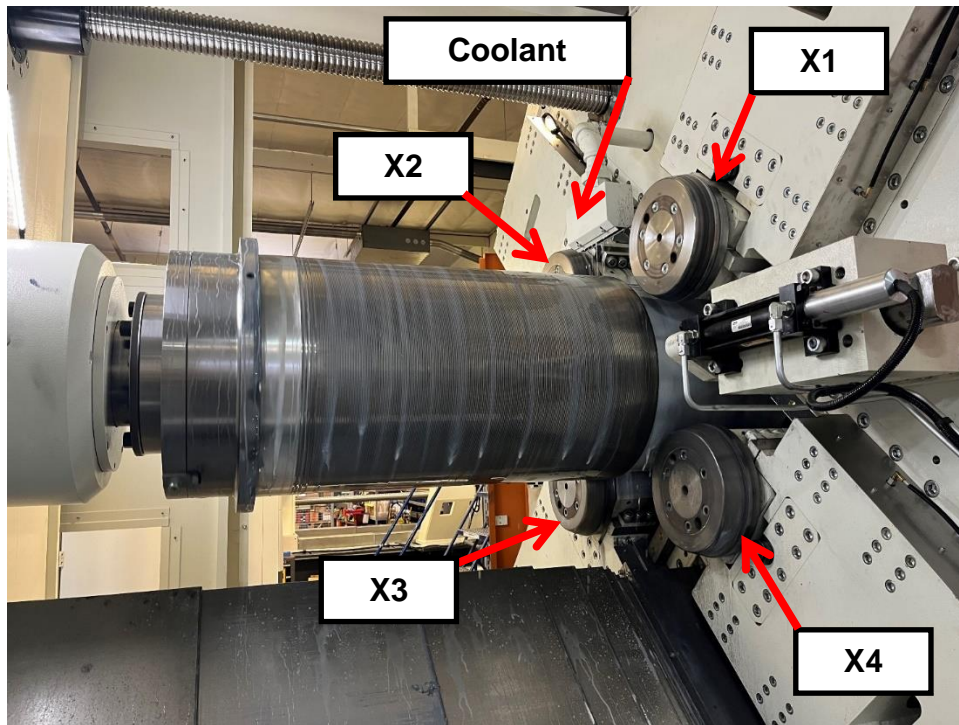

Part Catcher

The part catcher height can be setup for loading and unloading different diameter parts.

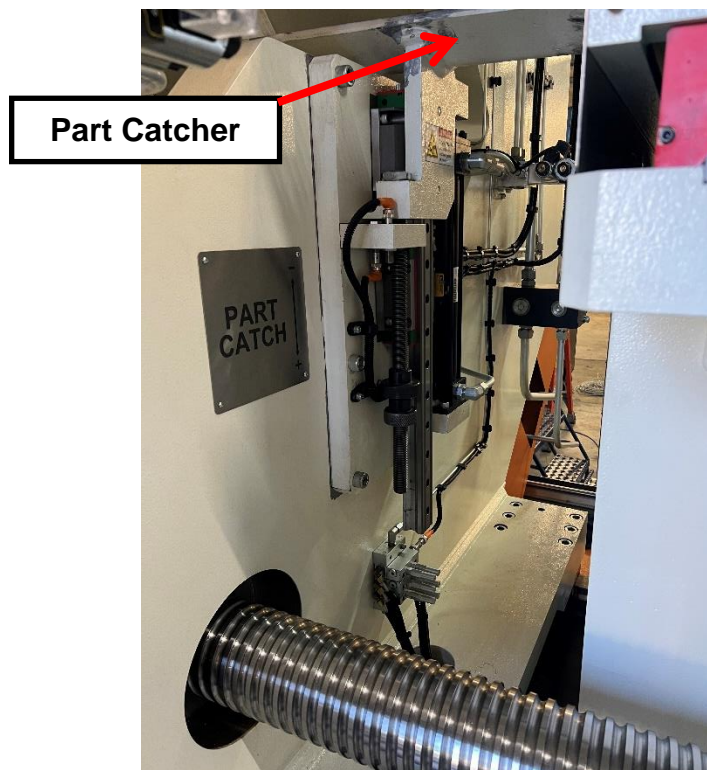

5.3.5 Spindle Motor (-080-)



The spindle is a 300 HP motor, and delivers power through a Gates Poly Chain belt. [VERIFY]

The spindle motor is mounted to a “belt tensioning plate”, and it can be moved to adjust the belt tension, and this process is described later in this section.

MJC recommends to:



1. Inspect the belt deflection every year to confirm that it is at the correct specification, if it is incorrect then do the re-tension belt procedure.
2. Also, do the re-tension belt procedure whenever the spindle motor is installed or swapped out.
3. Use an accurate tool to measure the belt tension, such as a belt tension guage.
4. Consider belts less than one year old as "new" for determining the correct belt tension.



MJC uses an external website to determine the belt tension for Gates Poly Chain belts.

Link: <https://www.gates.com/us/en/knowledge-center/calculators/polychain-tension-calculator.html>

The inputs for the calculation:

Belt Pitch (mm)	14mm
Belt Pitch Length (mm)	2520
Belt Width (mm)	68
DriveR Sprocket Grooves	75
DriveN Sprocket Grooves	112
Motor HP *	300
DriveR RPM *	1492
Center Distance	23.63" (600mm)
Static Tension per Strand	From 1374 to 1499 lbs
Rib/Strand Deflection Distance	0.37"
Rib/Strand Deflection Force	From 97 to 105 lbs
Sonic Tension Meter	From 90 to 94 hz





Warning: The next two processes may only be done with the machine power turned off, and proper lock-out-tag-out procedures in place.

Access the belt

In order to access the belt:

- Remove the (12) M8 bolts.
- Slide the belt cover out and away from its mounted position.

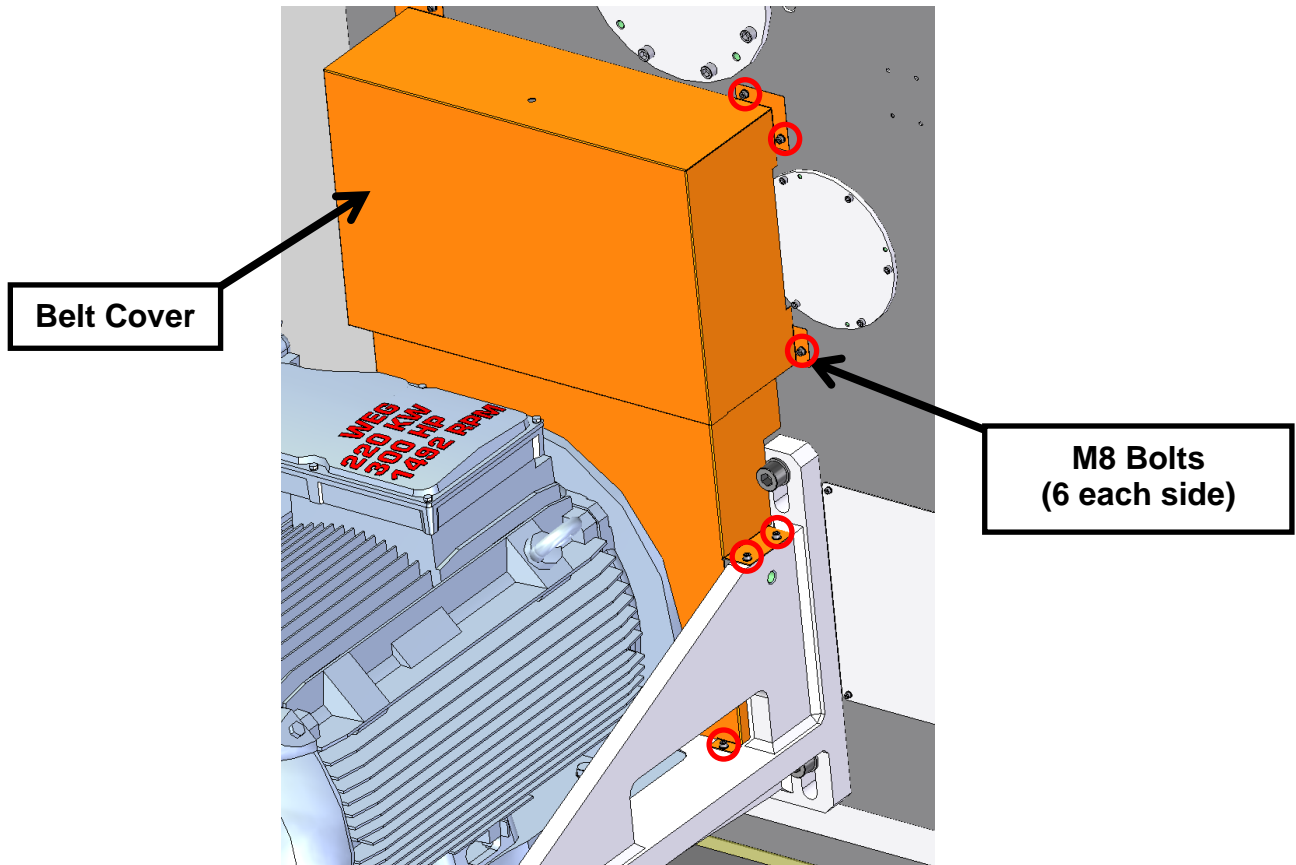

Only when the machine is turned off, and proper lock-out-tag-out procedures are in place, and the cover is removed, then the belt can be touched with a belt tension calibration tool.

DO NOT attempt to bypass any of these safety measures, or attempt to stick anything through the gaps in the belt cover while it is mounted to the machine.

Adjusting the belt tension:

- Loosen the (4) M30 bolts.
- EQUALLY rotate the (2) M24 nuts.
 - Clockwise for increased tension.
 - Counter-clockwise for decreased tension.
- Measure the belt deflection with the proper gauge or tool, and adjust the M24 nuts as necessary.
- Once the belt deflection is at the desired tension, then determine the squareness of the sprockets.
- Retighten the (4) M30 bolts.
- Reattach the belt covers.

The picture below does not show the belt tensioning plate, and the leveling M24 nut is underneath it.

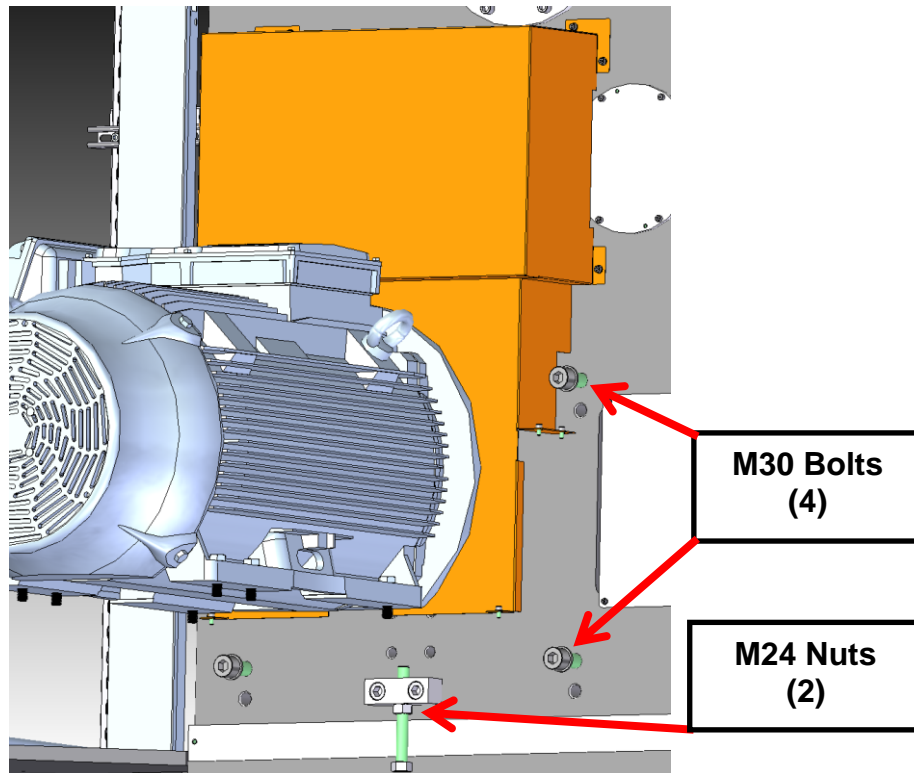

9. Check alignment

Proper alignment is essential for long Torque Team® V-belt life. Check belt alignment whenever you maintain or replace belts or whenever you remove or install sheaves. Limit misalignment to 1/2 degree or approximately 1/10 inch per foot of center distance.

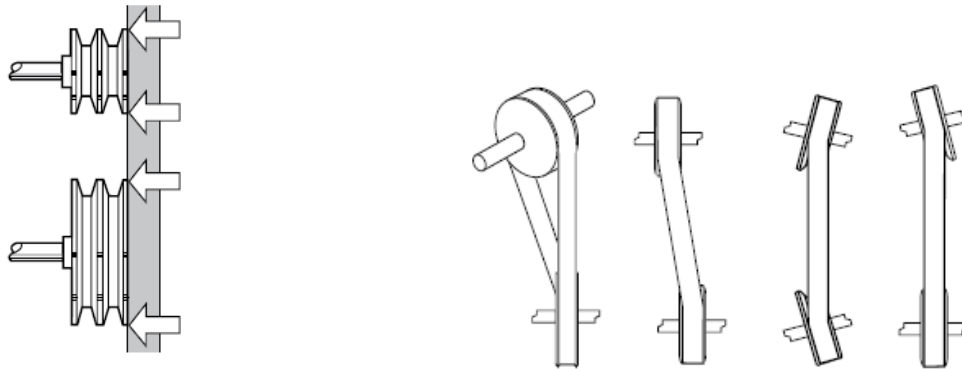

The illustration above shows the correct way to check alignment between two sheaves with a straight edge. Check both front and back alignment. Straight edge should touch sheaves at the four points indicated.

Non-parallel shafts or sheaves not aligned axially can cause angular misalignment.

5.3.6 Door Assembly (-120-)

This machine has a sliding door to protect the user during operation. It is locked into the closed position by an electronic door switch.



5.3.7 Operator Controls or HMI (-850-)

In this section the terms “operator controls”, “Human Machine Interface (HMI)”, “Machine Control Panel (MCP)”, “handwheel”, or “joystick” all bear the same meaning with safety procedures. The aforementioned devices are capable of controlling the machine, turning the spindle, moving slides, or activating tools on the machine.

MJC recommends to follow all OSHA, local safety regulations, and laws for cases that include but are not limited to: operating industrial equipment, using operator controls or HMI equipment.

Operator Controls (MCP or HMI)

The operator controls have all standard controls for operating metal spinning machines.

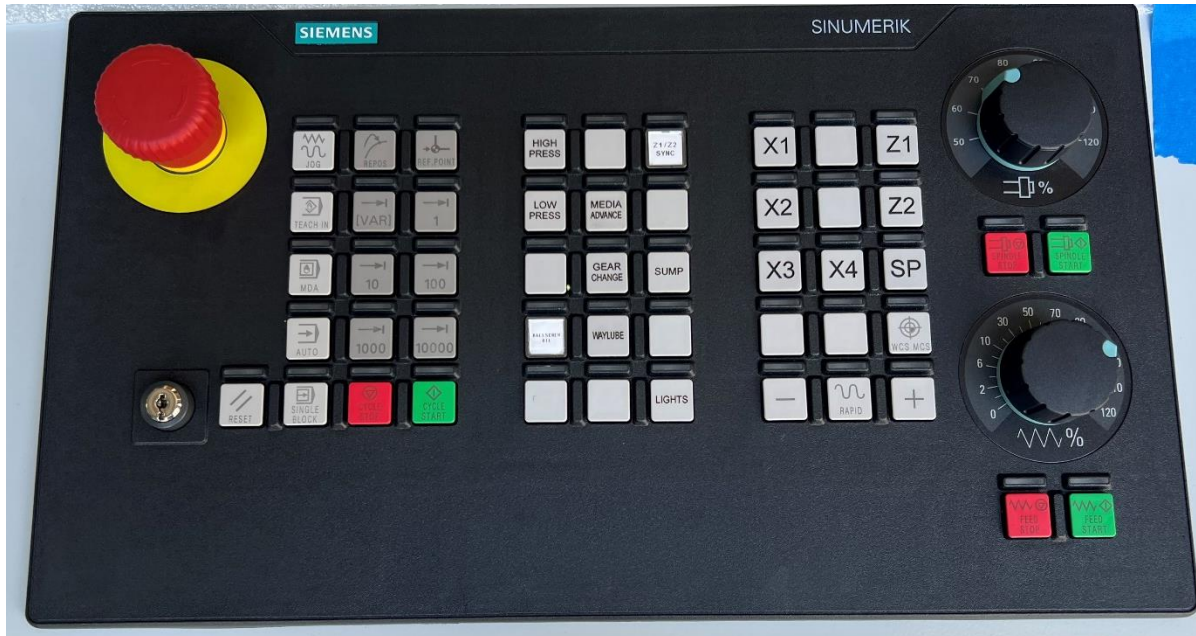

Below is a picture of the touch screen and keyboard.



Handwheel

The handwheel allows precise movement of the machine from a more flexible location.



Electrical Cabinet

The electrical cabinet contains all the electrical components and the CNC.

The left cabinet:



The middle cabinet:

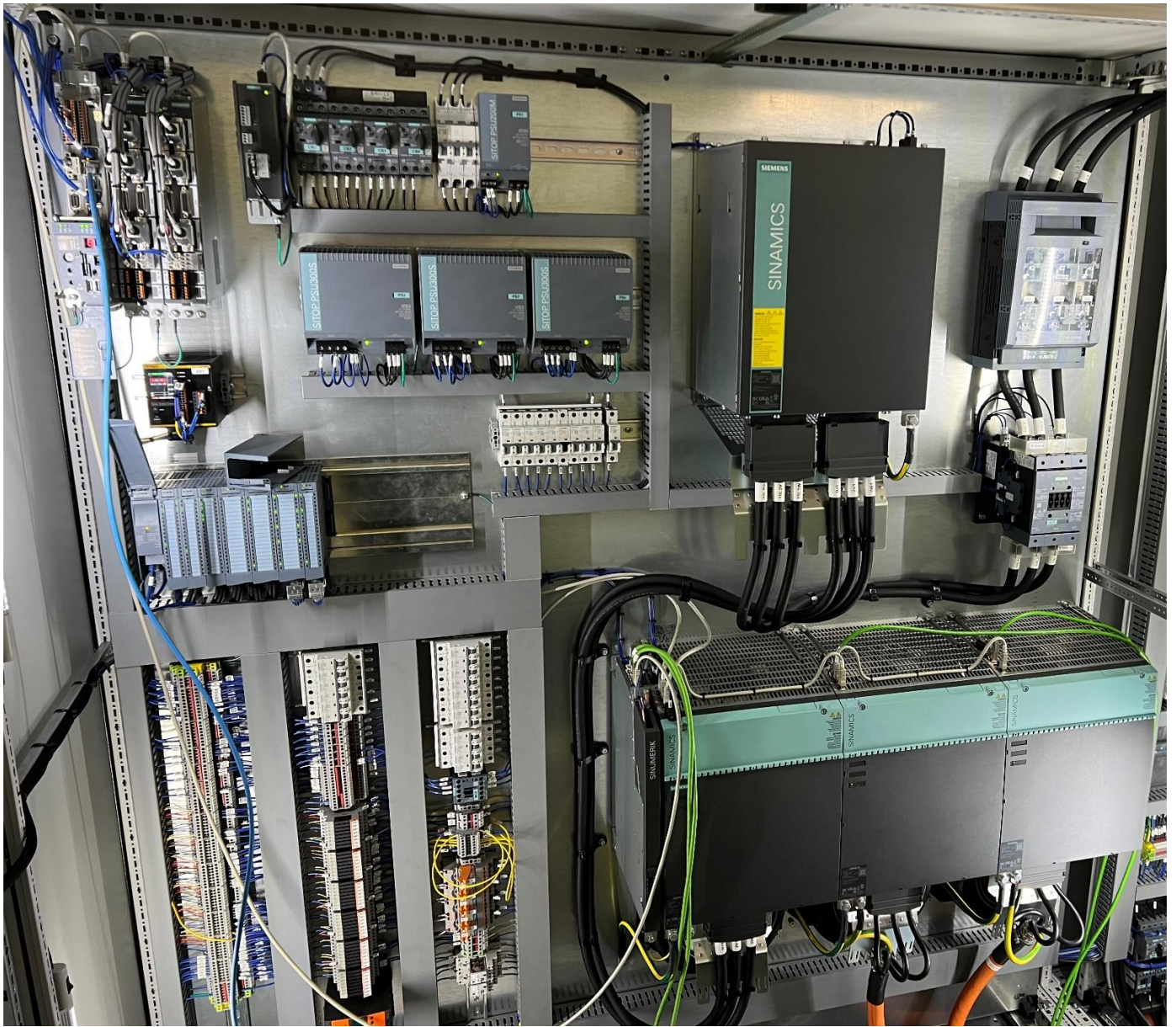

The right cabinet:

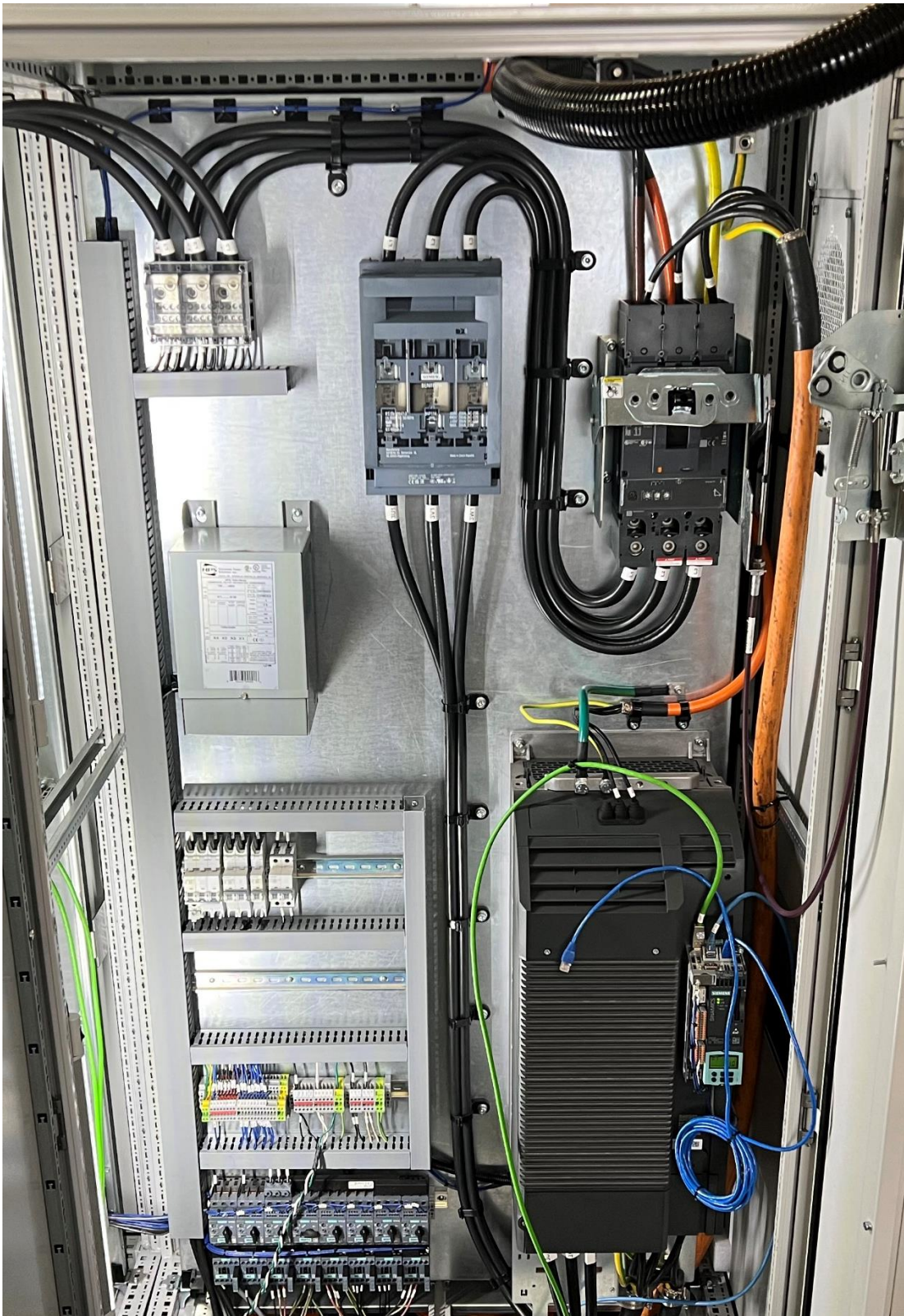

5.3.8 Green Hydraulic Power Unit (-950-)

The GHP provides energy efficient hydraulic power to the machine.

See the “Hydraulic Oil Change - Maintenance of the Oil Filter” section for instructions regarding hydraulic oil and filter replacement.



6. Included Software

MJC offers a variety of software packages depending on the machine purchased. Reference the external manuals for more details about software operation.

6.1 Input/Output Screen

This screen shows inputs and outputs of the machine, and is generally used to troubleshoot causes of faults or alarms. Green lights will indicate that the signal is currently set, or true.

MONITORIO
3000 Emergency stop
MJC ENGINEERING AND TECHNOLOGY, INC. Monitor IO v1.7 Oct 2020

<input type="checkbox"/> AUTO SELECT PB	<input checked="" type="checkbox"/> ALL PS OK	<input type="checkbox"/>	<input type="checkbox"/> JS RUN
<input type="checkbox"/> JOG SELECT PB	<input type="checkbox"/> FENCE DOOR1 SW1	<input type="checkbox"/>	<input type="checkbox"/> JS START SPLINE
<input type="checkbox"/> DOOR OPEN PB	<input type="checkbox"/> FENCE DOOR1 SW2	<input type="checkbox"/> DOOR 1 OPEN LS	<input type="checkbox"/> JS END SPLINE
<input type="checkbox"/> POWER ON	<input type="checkbox"/> FENCE DOOR2 SW1	<input type="checkbox"/> DOOR 1 CLOSED LS	<input type="checkbox"/> JS ADD POINT
<input type="checkbox"/> DOOR CLOSED PB	<input type="checkbox"/> FENCE DOOR2 SW2	<input type="checkbox"/> DOOR 2 OPEN LS	<input type="checkbox"/> RESET
<input type="checkbox"/> RESTART PB	<input type="checkbox"/> SLIDE HYD PS	<input type="checkbox"/> DOOR 2 CLOSED LS	<input type="checkbox"/> JS JOG
<input type="checkbox"/> AUTO/START PB	<input type="checkbox"/> SPINDLE HYD PS	<input checked="" type="checkbox"/> DOOR BYPASS	<input type="checkbox"/> JS MDA
<input type="checkbox"/> SPINDLE LUBE FLOW SW	<input type="checkbox"/> MACHINE FRAME PS	<input type="checkbox"/>	<input type="checkbox"/> JS CYCLE START
<input type="checkbox"/> SPINDLE LUBE FILTER OK	<input type="checkbox"/> HW ENABLE	<input type="checkbox"/>	
<input type="checkbox"/>	<input type="checkbox"/> MAINTENANCE MODE	<input type="checkbox"/>	
<input type="checkbox"/>	<input checked="" type="checkbox"/> ALL OL OK	<input checked="" type="checkbox"/> HYDRAULIC TANK LOW LEVEL	
<input type="checkbox"/> RESET PB	<input type="checkbox"/> TAILSTOCK PRESSURE SW	<input type="checkbox"/> HYDRAULIC HIGH TEMP	
<input type="checkbox"/> TS CLOSE PB/JS	<input type="checkbox"/> TAILSTOCK BACK LS	<input checked="" type="checkbox"/> GREASE PUMP FLOW SW	
<input type="checkbox"/> TS OPEN PB/JS	<input type="checkbox"/> SPINDLE LUBE CONFIRM 1 FRQ	<input type="checkbox"/> RETURN FILTER	
<input type="checkbox"/>	<input type="checkbox"/> SPINDLE LUBE CONFIRM 2 BAC	<input checked="" type="checkbox"/> PRESSURE FILTER	
<input checked="" type="checkbox"/> TURRET DOWN LS	<input type="checkbox"/>	<input checked="" type="checkbox"/>	

new alarms

MONITORIO
3000 Emergency stop
MJC ENGINEERING AND TECHNOLOGY, INC. Monitor IO v1.7 Oct 2020

<input type="checkbox"/> SP BLOWER	<input checked="" type="checkbox"/> BUP FORWARD	<input type="checkbox"/> START SPLINE LED	<input type="checkbox"/>
<input type="checkbox"/> GHP FAN	<input type="checkbox"/> BUP BACK	<input type="checkbox"/> ZONE ON LED	<input type="checkbox"/>
<input type="checkbox"/> COOLANT PUMP	<input type="checkbox"/> EJECTOR FORWARD	<input checked="" type="checkbox"/> JOG LED	<input type="checkbox"/>
<input type="checkbox"/> SPINDLE LUBE	<input type="checkbox"/> EJECTOR BACK	<input type="checkbox"/> MDA LED	<input type="checkbox"/>
<input type="checkbox"/>	<input type="checkbox"/> ENABLE MUS MACHINE FRAME	<input checked="" type="checkbox"/> CNC READY LED	<input type="checkbox"/>
<input type="checkbox"/> HYD LOAD / HYD RUN METER	<input type="checkbox"/> X AXIS ENABLE	<input type="checkbox"/> HYD COOLING SOLENOID	<input type="checkbox"/>
<input type="checkbox"/> SP RUN TIME METER	<input type="checkbox"/> ENABLE MUS SPINDLE	<input type="checkbox"/> TURRET UP	<input type="checkbox"/>
<input type="checkbox"/>	<input type="checkbox"/> ACCUMULATOR DUMP	<input checked="" type="checkbox"/> TURRET DOWN	<input type="checkbox"/>
<input type="checkbox"/>	<input type="checkbox"/> TAILSTOCK CLOSE	<input type="checkbox"/> OFF 1	<input type="checkbox"/>
<input type="checkbox"/>	<input type="checkbox"/> TAILSTOCK OPEN	<input type="checkbox"/> OFF 3	<input type="checkbox"/>
<input type="checkbox"/>	<input type="checkbox"/> DUMP 2	<input type="checkbox"/> PRESSURE 1 PB LED	<input type="checkbox"/>
<input type="checkbox"/>	<input type="checkbox"/>	<input type="checkbox"/> PRESSURE 2 PB LED	<input type="checkbox"/>
<input type="checkbox"/> TS UNLOCK	<input type="checkbox"/>	<input type="checkbox"/> PRESSURE 3 PB LED	<input type="checkbox"/>
<input type="checkbox"/> COOLANT 1 SPRAY	<input type="checkbox"/>	<input type="checkbox"/> PRESSURE 4 PB LED	<input type="checkbox"/>
<input type="checkbox"/> GREASE PUMP	<input type="checkbox"/> GEAR STAGE 1	<input checked="" type="checkbox"/> DOOR UNLOCK (FENCE)	<input type="checkbox"/>
<input type="checkbox"/> COOLANT 2 SPRAY	<input type="checkbox"/> GEAR STAGE 2	<input type="checkbox"/> BUP FLOAT	<input type="checkbox"/>

new alarms



6.2 SpinCAD 4.0

The latest MJC custom CAD program to create metal spinning programs, and generate G code for a large variety of machines.

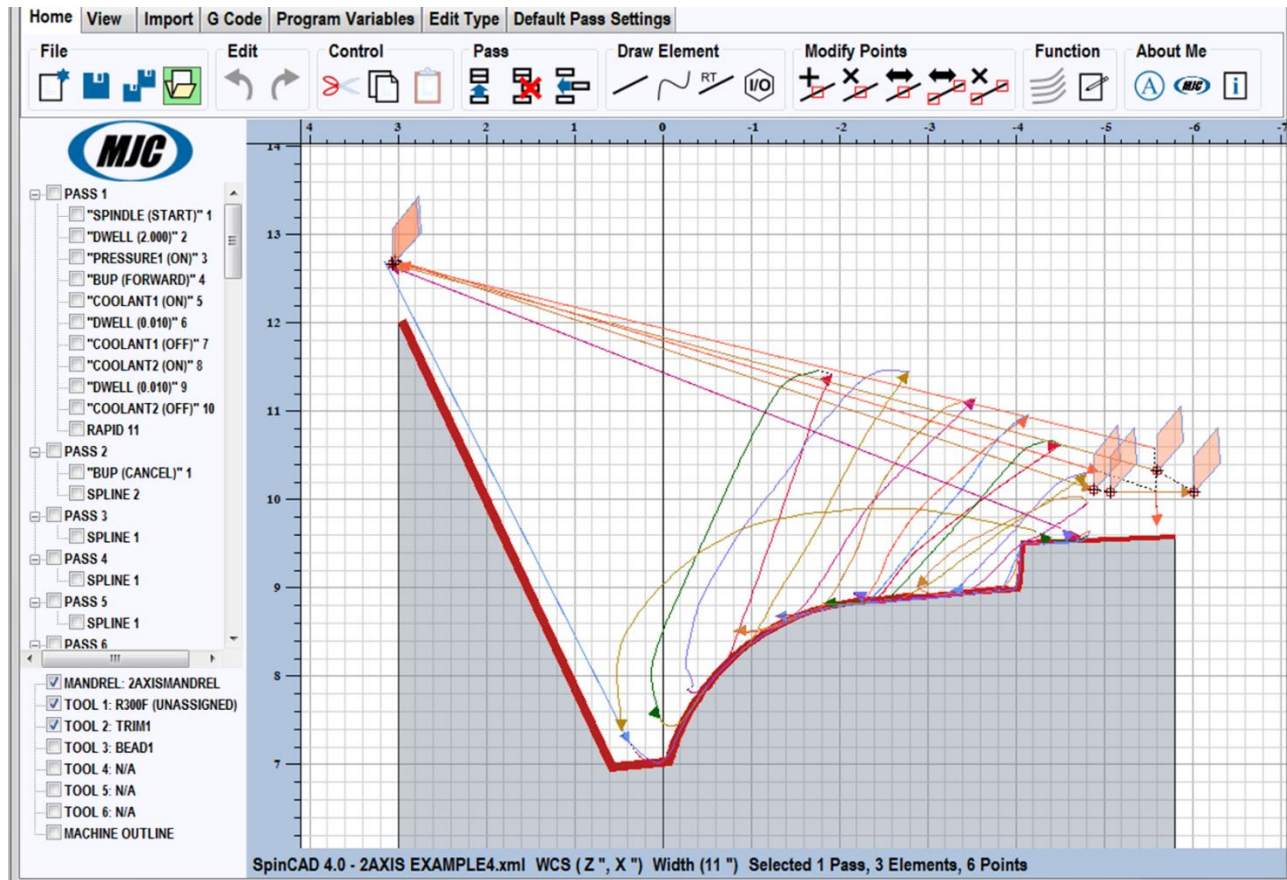

7. Maintenance & Inspection

7.1 General Information



Before carrying out maintenance and inspection work:

- Switch off the hydraulic system.
- Discharge the hydraulic accumulators.
- Switch off all gas and oxygen supply if the machine is equipped with torches.
- Switch off all shop air if the machine has any pneumatic equipment.
- Switch off the key-operated switch.
- Switch off the mains switch and provide a safeguard against unintentional energizing!
- Only trained experts of the respected fields of mechanics, hydraulic, pneumatic and electronics are allowed to carry out functionality checks and inspection works.



Please refer to the safety section when performing maintenance and inspection work.

Failures caused by insufficient or incorrect maintenance may lead to very high repair costs and long downtimes of the machine. Therefore, periodical maintenance is imperative.

Besides various other factors, the operational safety and the overall life of the machine depends on correct maintenance.

The following “List of Maintenance and Inspection” contains time interval and maintenance instructions for the normal use of the machine.

The time interval is based on an 8-hour operating day. If the operating hours indicated is not reached during the corresponding period, the period may be extended accordingly.

Because of the different operating conditions, it is impossible to determine the frequency of wear and tear checks, inspections, maintenance and repair. A schedule of routine inspections is recommended based on the operating conditions.

7.2 List of Maintenance and Inspections Items

Regularly:

- Check the condition and level of hydraulic oil, filters, grease, and other lubricants as specified in the “Oil and Lubrication Plan” section.
- Check the proper functionality of controls and sensors, and note anything out of the ordinary.
- Do not use compressed air on the machine to remove dirt, debris, or chips. Use only cleaning cloths and vacuums.
- If there is a change to existing G code, or new G code created, then back up the files.

Daily:

- Check for leaks in or around the machine.
- Check that the working pressure of the hydraulic system is at the proper level for operation.
- Check the hydraulic oil for signs of ageing, dirt, contaminants, or water.
- Check the hydraulic oil filter is clean enough for normal operation, and only when the hydraulic system is powered off. Some machines have a sensor equipped to indicate “filter dirty” signal.
- Check that the temperature and/or flow meters are at the proper level for operation.
- Check the proper function of emergency devices such as: E-Stop buttons, fences, etc.

Weekly:

- Clean the way covers, and briefly inspect for any possible damage.
- Check the sump pump and coolant pit are clear of contaminants. If it exists, then clean or remove the contaminants. Verify that the coolant mix is the expected percentage. If any other liquid is found during inspection, then determine if the coolant can continue being used, or if it is compromised then replace the entire volume of coolant.

Monthly:

- Inspect way covers for proper function, and lubricate with a small amount of WD40, if necessary.
- **Only when the machine AND mains power are off, inspect the following items:**
- Check for dust buildup in the electrical panel. If it exists, then wipe down with a clean cloth.

Semi-Annual:

- Replace all hydraulic oil and filters on the machine.
- Check all hoses and lubrication lines for cracking.

Annual:

- Check all electric motors for wear and tear. Then apply grease to the motor bearings using the manufacture’s specification.
- **Only when the machine AND mains power are off, inspect the following items:**
- Check the spindle belt for wear and tear. Measure the belt tension and adjust to match the specification in the “Spindle Motor – Adjusting the belt tension” section.
- Check all electrical terminals, plug-in connections, cables and lines for a firm seat.
- Check all electrical contacts for corrosion.



7.3 Machine Required Oil and Lubrication

In this section the terms “oil”, “grease”, “lube”, “lubrication”, or “lubricants” all bear the same meaning with safety procedures, and are intended to only be used to lubricate moving parts on the machine.

Safety Procedures

MJC recommends to follow all OSHA, local safety regulations, and laws for cases that include but are not limited to: storing lubricants, application of lubricants on a machine, proper disposal of oil or lubricants, and the safety steps to remove or clean off harmful substances from the human body.

Storage of Lubricants

MJC recommends to store lubricants in a cool, dry place, and within sealed containers to prevent any contamination by dust, debris, humidity, or oxidation. Refer to the aforementioned safety procedures.

Initial Status of Lubrication on the Machine

The machine has been provided with correct oil and lubricants during assembly at MJC’s factory, or at the manufacturer’s site for purchased parts like motors or gearboxes, unless otherwise stated.

Alternative Lubricants

If the lubricants on the “Oil and Lubrication Schedule” are not available, then alternative lubricants can be used, as long as they match the same specifications.

However, MJC does not assume any responsibility or liability for damage or malfunction that may occur, if an alternative lubricant was used.

Regular Maintenance

Check and fill the lubricants at the correct time intervals specified in the “Oil and Lubrication Schedule”. Insufficient lubrication will cause excessive wear, and shorten the service life of the machine.

7.3.1 Oil and Lubrication Schedule

Location	Type	Quantity	Interval
GHP / hydraulic oil*	ISO 32	200 gallons	6 months
Headstock / Spindle oil*	ISO 100	35 gallons	Monthly
Headstock Z1 Z2 lube Zerk fittings	SKF LGLT 2	2 hand pumps	Monthly
Tailstock live center	SKF LGLT 2	4 hand pumps	2 months
Tailstock grease pump and reservoir unit	SKF LGLT 2	2 liters	When low
Slide grease pump and reservoir unit	SKF LGLT 2	2 liters	When low
Ball screw oil pump and reservoir unit	ISO 100	2 liters	When low
Heat exchanger for GHP and Headstock	Facility water 50 lpm at 3–30 bar	Continuous supply	When machine is in operation
Slide way cover	WD40	As needed	Monthly
Part lube (paint roller)	ChemArrow 3718	Every part	As needed
Flooded coolant	HOCUT 795 (7–12% in water)	540 gallons	Check weekly

*Reference the “Hydraulic Oil Change” section for inspecting, filling, and changing filters.



7.3.2 Machine Oil and Lubrication Locations

Overview of the Machine

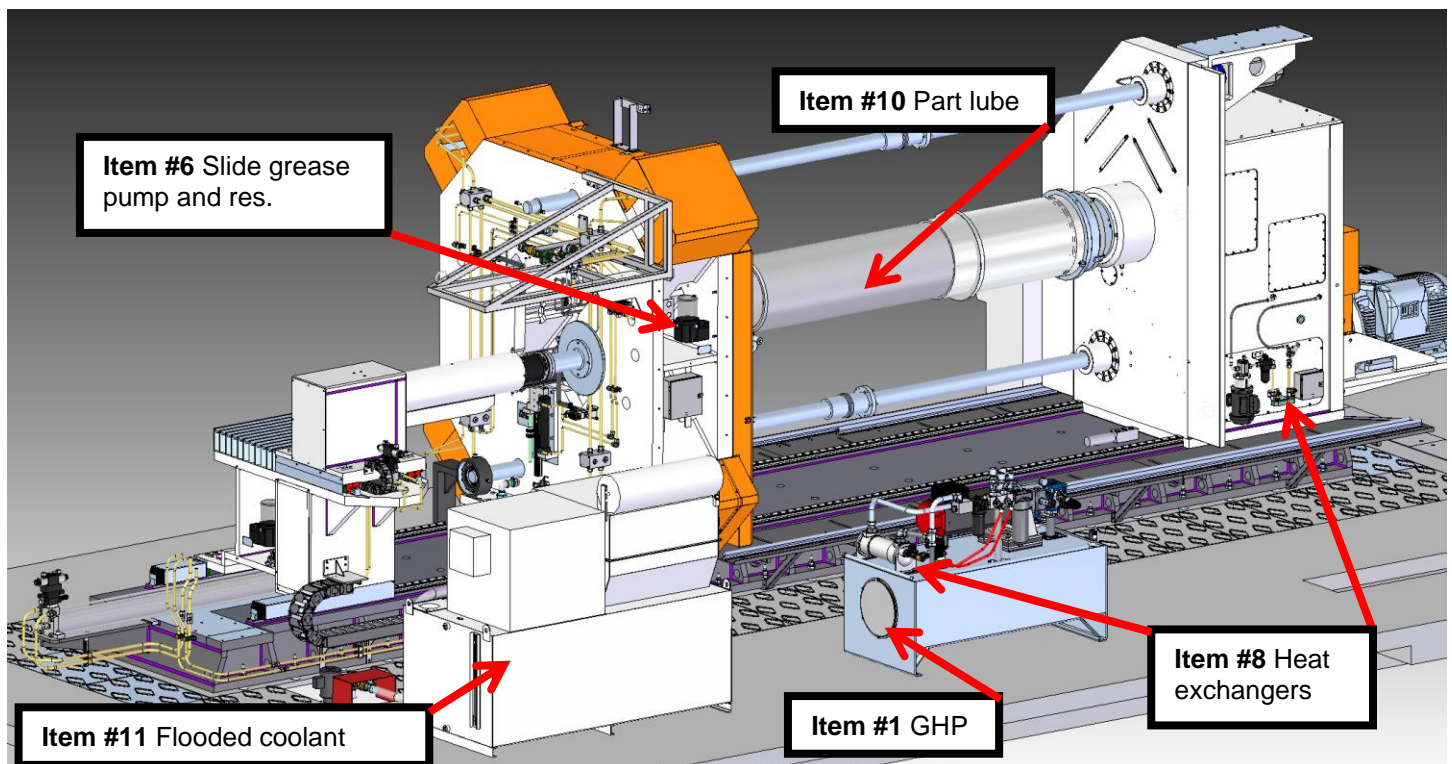
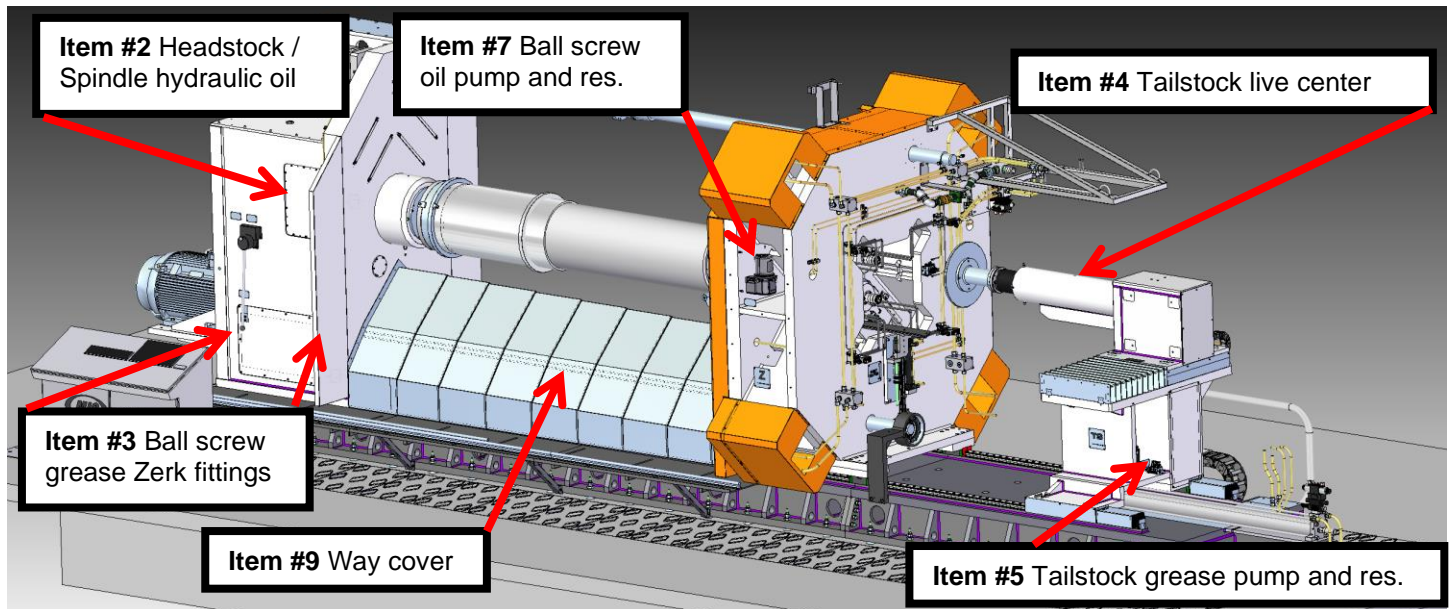

GHP

Refer to the section “Hydraulic Oil Change”.

Headstock / Spindle oil

Refer to the section “Hydraulic Oil Change”.

Tailstock live center

There is one Zerk fitting on the top of the body of the tailstock assembly.

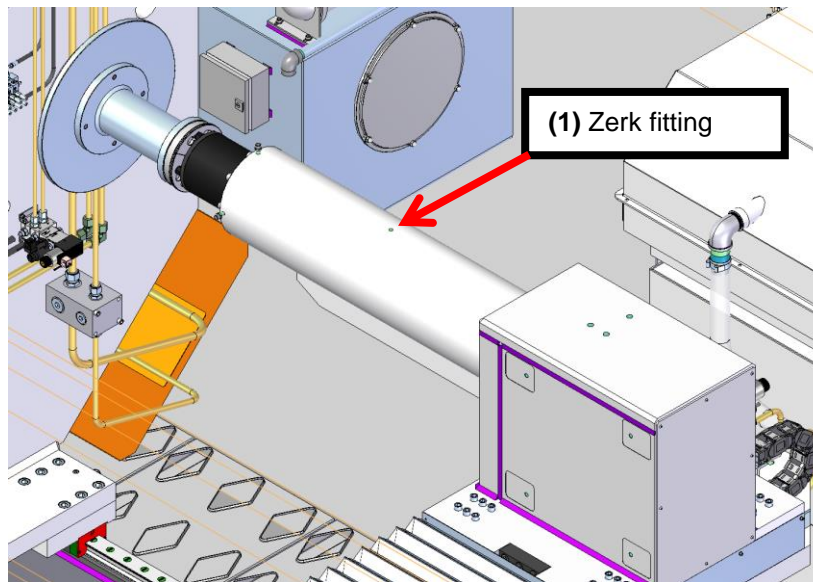
**Tailstock grease pump and reservoir unit**

This unit supplies grease to all the linear bearings on the Tailstock.

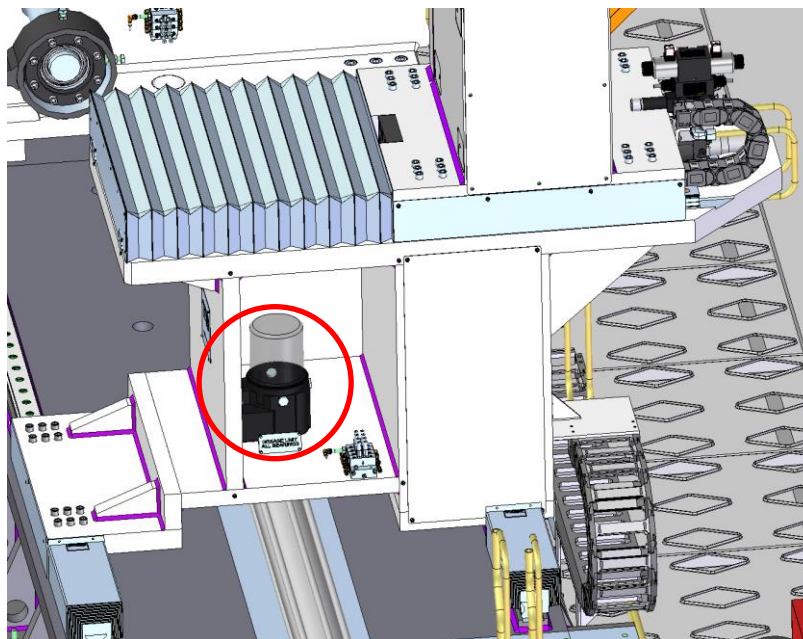

Slide grease pump and reservoir unit

This unit supplies grease to all the linear bearings on the Main Slide, and it is located behind the X2 side panel.

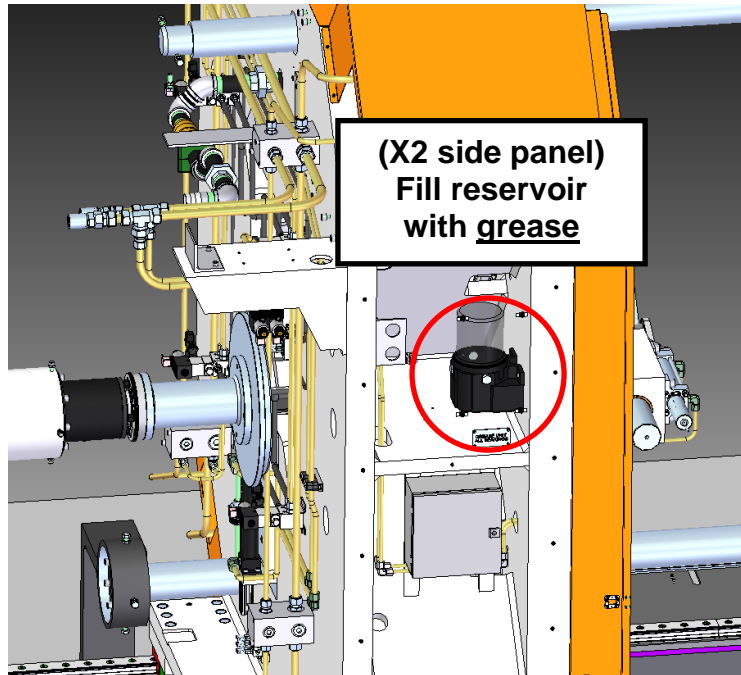

Ball screw oil pump and reservoir unit

This unit supplies oil to the two ball screw housings Z1 Z2, and it is located behind the X1 side panel.

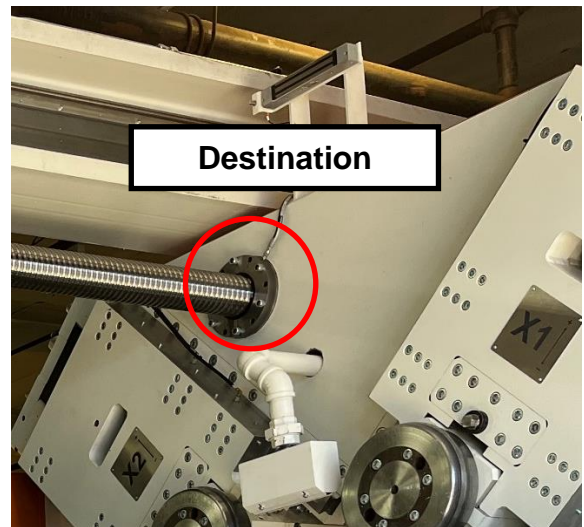
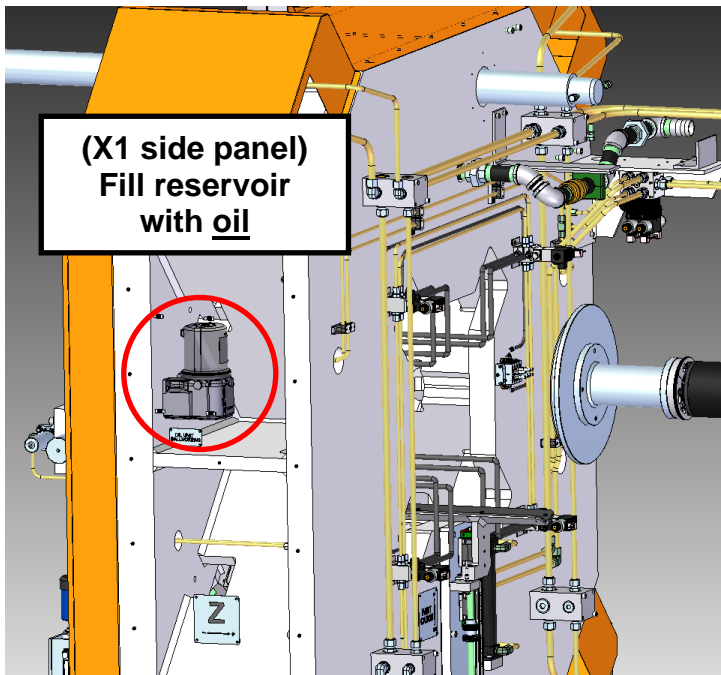

Heat exchangers

There are two heat exchangers on the machine, one on the GHP and one for the Headstock / Spindle oil. There are temperature sensors that will sound an alarm if an overtemperature event is detected. The facility water for cooling must be at least: 10 gpm, minimum pressure 2 bar, maximum pressure 30 bar, and the maximum temperature is 23°C for safe operation.

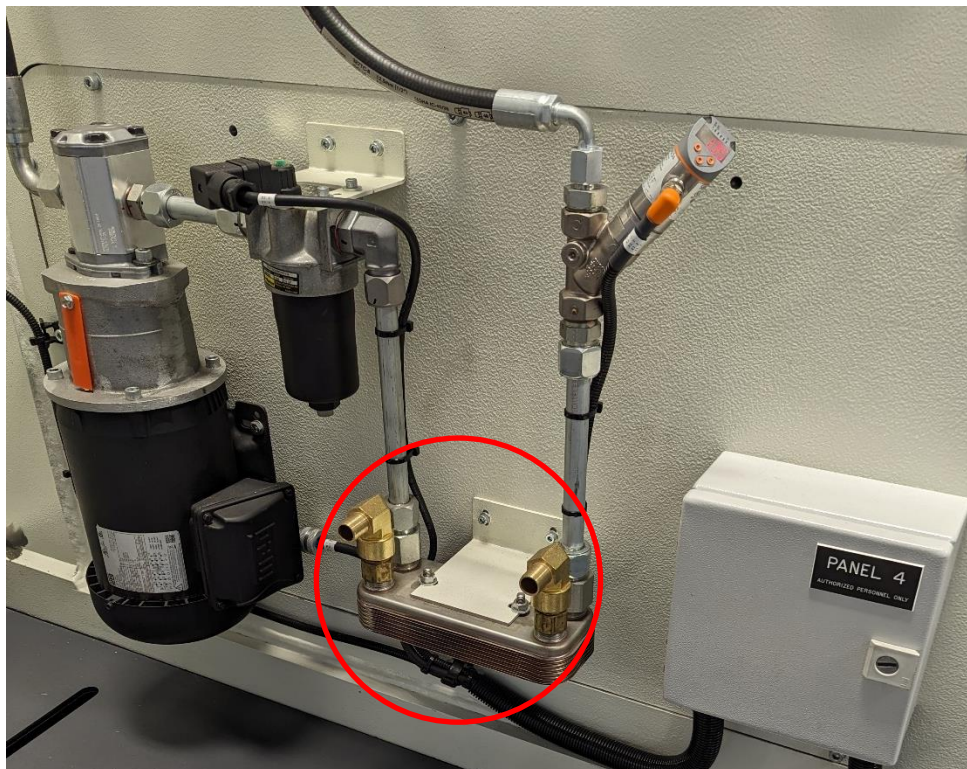
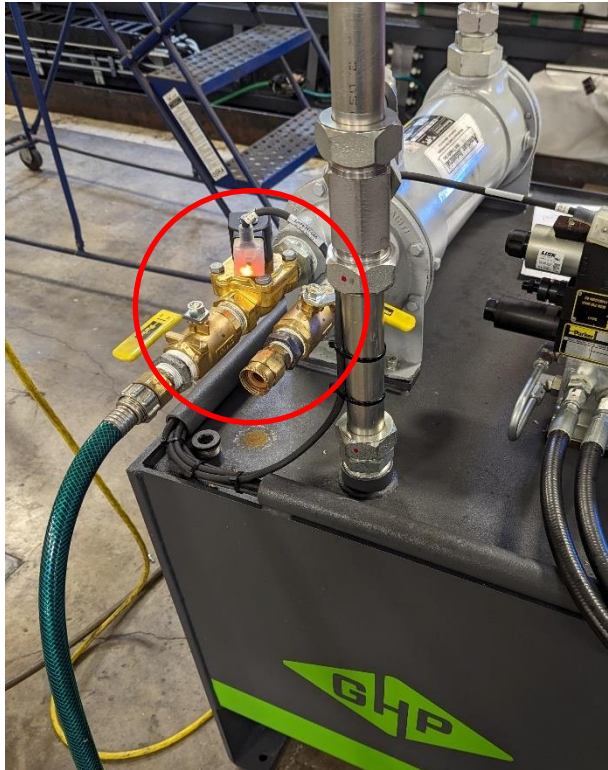

Headstock Z1 Z2 Zerk fittings

There are two Zerk fittings on the headstock that need grease for the two ball screw housings Z1 and Z2. The design of these ball screw housings on the headstock are different and require grease, whereas the ball screw housings on the main slide require hydraulic oil from the oil pump and reservoir unit.

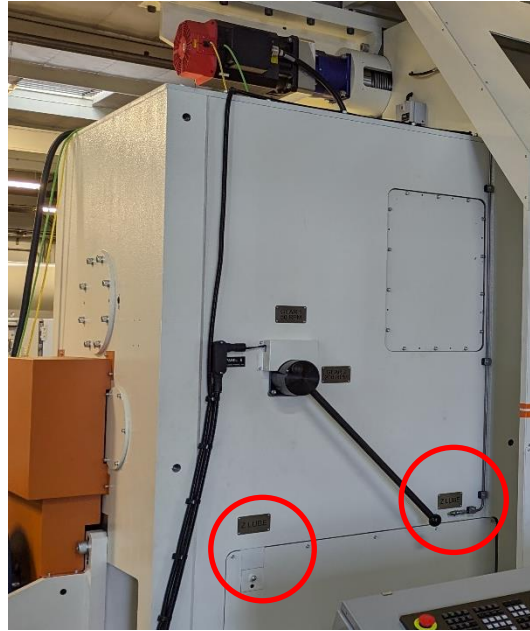

Slide way cover

This way cover needs to be routinely sprayed with WD40 every month to prevent rust from building up.

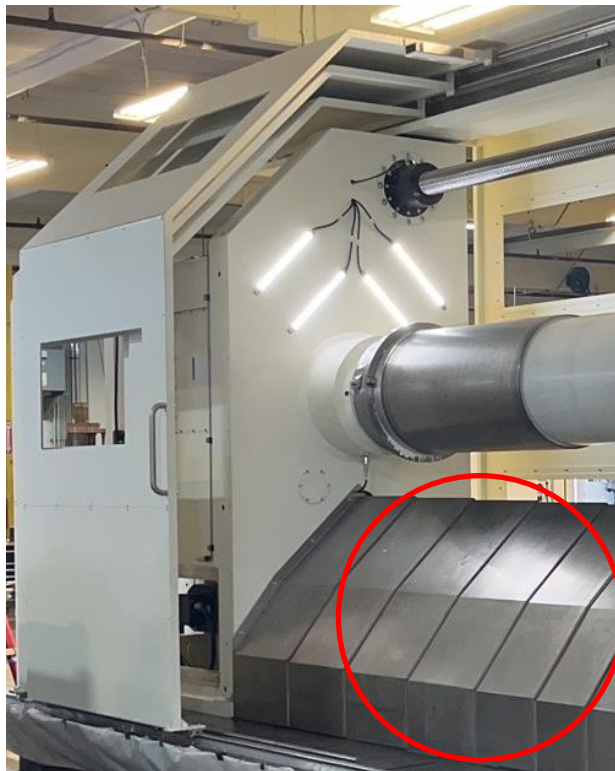

Part lube

This part lube is applied to the mandrel with a paint roller prior to loading a part.

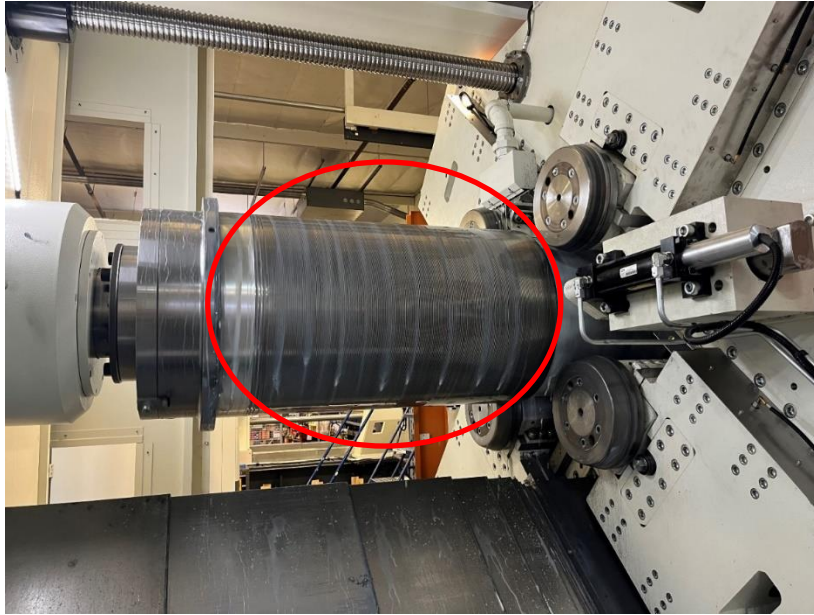
**Flooded coolant**

This flooded coolant continuously flows to cool down the mandrel, part, and the rollers. The filter system is a Jorgensen paper screen coolant pump and reservoir unit, with part number "JOR 42-6539".

MJC recommends to use HOCUT 795 at 7-12% mix with water, and it must be at least 7% to prevent the machine from rusting.



7.4 Hydraulic Oil Change

Check daily that the hydraulic oil shows no sign of ageing, dirt, contaminants, or water.

Check daily that the hydraulic oil filter is clean for normal operation, and only when the hydraulic system is powered off. Some machines have a sensor equipped to indicate “filter dirty” signal.

If the filter is dirty, and if it is not replaced immediately, then contamination of the hydraulic oil may occur.

If there is high moisture content in the air, then water contamination of the hydraulic oil may occur. This usually appears when moisture settles in the surfaces of the tank above the hydraulic oil level.

This moisture in the tank may also cause rust, and rust will further contaminate the oil.

If water or rust is present, then:

- Empty all of the hydraulic oil immediately.
- This includes the tank, accumulators, the hydraulic lines and pipes on the machine.
- Find the cause of the problem and eliminate.
- Fill the tank with new hydraulic oil.

Water reduces the viscosity of the hydraulic oil and causes emulsification of the oil.

If enough water travels into the hydraulic cylinders, then there is a chance of air bubbles being introduced into the system, and this may cause cavitation and damage pump gears and seals.

MJC does not assume any responsibility or liability for damage or malfunction that may occur due to contamination of the hydraulic oil.

For oil type and quantity reference the “Oil and Lubrication Schedule” section.

7.4.1 Maintenance of the Oil Filter

The service life of the filter element is dependent on the rate of contaminants that are caught.

Replace the filter element at each oil change, or when an inspection deems the filter is dirty.

The spindle breather filter is on top of the headstock, and the lube filter is on the side near the heat exchanger.

GHP Pressure Filter: Parker 941040Q

GHP Return Filter: Parker 936701Q

GHP Breather Filter: LDI DC-3-B

Headstock / Spindle Lube Filter: Parker 936712Q

Headstock / Spindle Breather Filter: MMC 9833K16



GHP filter locations

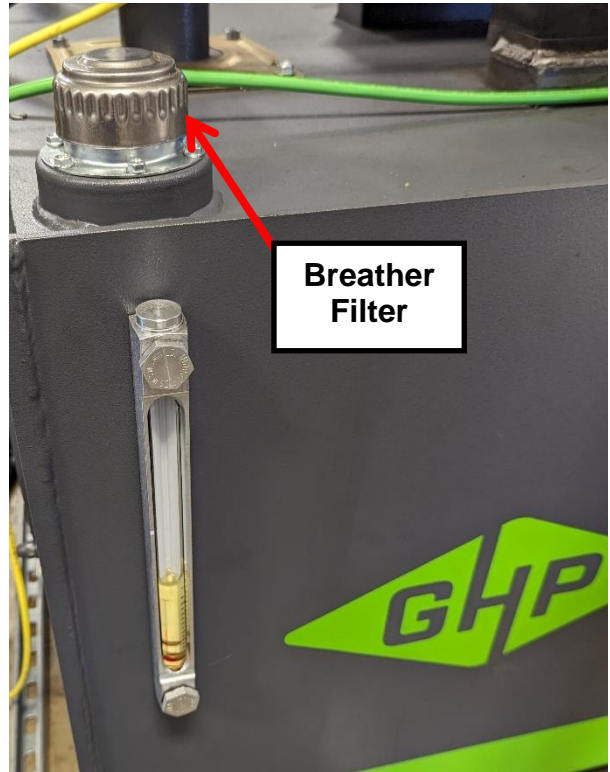
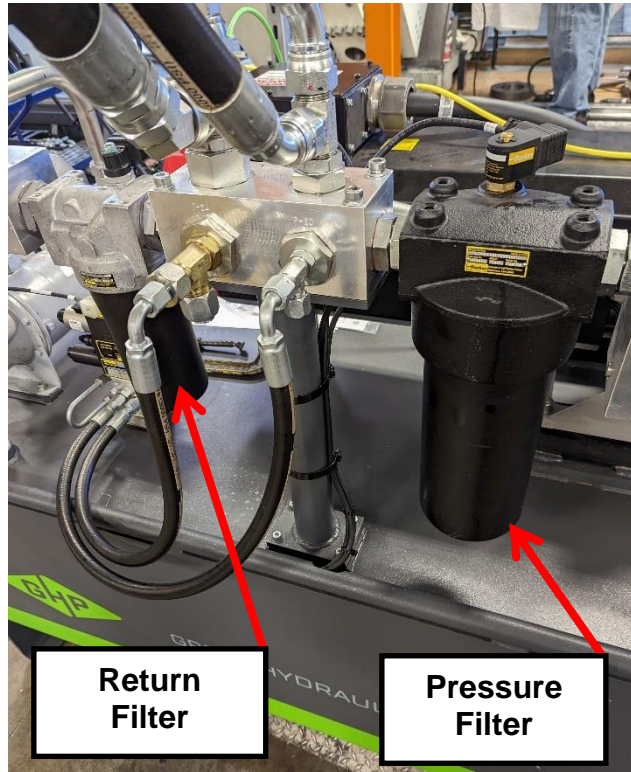

Headstock / Spindle lube filter locations

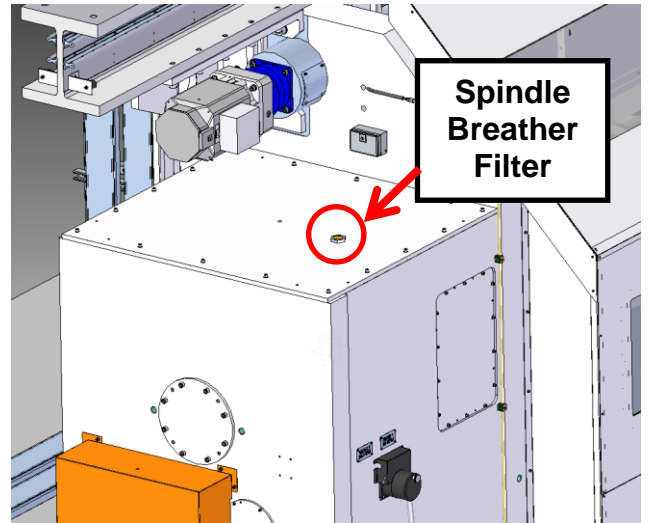
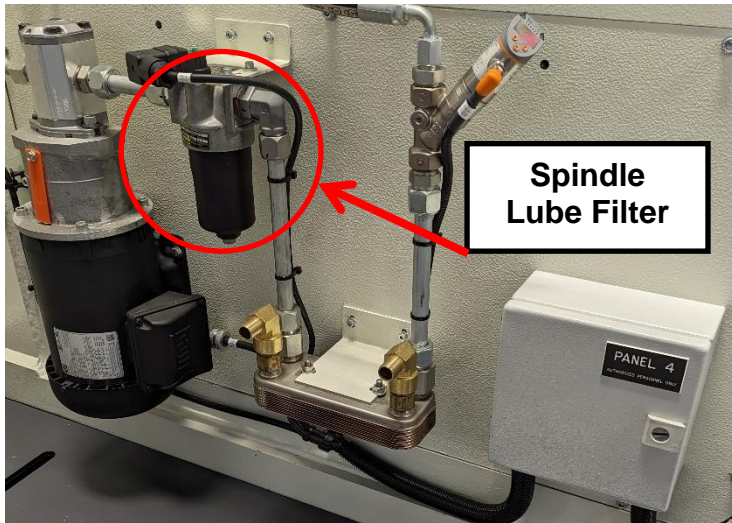

8. External Manuals

Siemens Manuals

9. SpinCAD Manuals

10. Spare Parts List

11. Schematics and Drawings

12. Terms and Conditions

The terms and conditions start on the following page.



“US Manufacturer of High Quality CNC Spinning Equipment”

MJC TERMS AND CONDITIONS OF SALE
(06-2012 Version)

Except as otherwise agreed by MJC Engineering and Technology, Inc. (“Seller” or “MJC”) in writing, the following terms and conditions (“Document”) will apply to all orders received and all sales made by Seller.

1. General. The terms and conditions set forth in this Document apply to all quotations made and all purchase orders entered into by Seller, and acceptance by Seller of any order by confirmation or commencement of performance shall be on the basis of these terms and conditions, even though no reference is made to these terms and conditions at the time of acceptance. Any term or condition in any printed form of Buyer, including but not limited to any order, confirmation or other document, which is in any way inconsistent with or in addition to the terms and conditions set forth in this Document is expressly rejected, and Seller’s acceptance of any offer or order of Buyer is expressly made in reliance on Buyer’s assent to all terms and conditions set forth in this Document. If Buyer objects to any of the terms and conditions set forth in this Document, such objection must be made in writing and received by Seller within ten (10) calendar days after placing a purchase order. Failure to so object shall be conclusively deemed to be acceptance of the terms and conditions set forth in this Document. Seller’s failure to object to any term or condition in any oral or written communication from Buyer shall not constitute an acceptance of any term or condition contained in any such communication or a waiver of any term or condition set forth in this Document. Any changes to the terms and conditions set forth in this Document must specifically be agreed to in writing by Seller to become binding on Seller.

2. Acceptance of Orders. All orders from Buyer are subject to acceptance by Seller, and Seller reserves the right to accept or reject any orders from Buyer. Seller’s products are custom designed and manufactured metal spinning and production based equipment (“Products”). As such, significant input from the Buyer on specifications and intended usage may be required by Seller, and Buyer, upon request of Seller, will promptly furnish to Seller any requested information regarding such matters as intended usage, desired specifications, contemplated implementation, etc.

3. Prices. The sale prices for the Products are accepted as stated on Seller’s order acknowledgment and will include the cost of Seller’s usual factory tests and inspections. The prices set forth are not subject to trade or other discounts. All quotations of Seller expire thirty (30) calendar days from the date given. Except as otherwise expressly stated in this Document or any accompanying order acknowledgement, any service calls or other service work performed by Seller shall be at Buyer’s expense in accordance with Seller’s standard rates for such services. Buyer acknowledges that the pricing of the Products and services and other terms and conditions set forth in this Document have been set based on the sections of this Document providing for an agreed upon allocation of risk for any defective Products or services between Buyer and Seller. Buyer further acknowledges that the pricing and the terms would have been different if there had been a different allocation of risk. All installation costs for the Products shall be the sole responsibility of Buyer, and Buyer will be solely responsible for such installation although Seller, upon request of the Buyer, will furnish Buyer with recommended instructions for installing the Products.

4. Transportation. All sales are made F.O.B. shipping point for U.S. based sales and as mutually agreed by Seller and Buyer for international sales. Seller’s title passes to Buyer upon making delivery of the Products purchased to the carrier at the shipping point in good condition. All claims for loss or damage during shipping must be filed by Buyer with the carrier. Unless specific instructions are given by Buyer in writing, Seller reserves the right to select the carrier and routing. No loss or damage during transit will relieve Buyer of any obligation, including the obligation of timely payment. Seller shall only be obligated to comply with the minimum packaging requirements customarily required by the applicable mode of transportation and carrier; any additional packaging requirements requested in writing by the Buyer shall be at Buyer’s expense.

5. Delivery and Acceptance. Delivery or shipping dates are approximate only and merely represent Seller’s reasonable estimate of the time required to make delivery or shipment. Time is not of the essence with respect to the transactions covered by this Document, except for Buyer’s obligation to make all related payments in a timely manner. Seller will not be liable for any loss or expense (incidental, direct, indirect, economic, consequential or otherwise) incurred by Buyer as a result of any delay in delivery for any reason other than the arbitrary refusal by Seller to perform. If Buyer is required to pay with a letter of credit, time of delivery shall only be measured as commencing upon actual receipt of an acceptable letter of credit by Seller. Seller may condition delivery of Products including all equipment and machinery upon Buyer’s actual inspection, testing and acceptance in writing of the equipment at Seller’s manufacturing facility.

6. Taxes. Unless otherwise specifically provided for in writing in a quotation or order acknowledgment of Seller, the amount of any present or future sales, revenue, use, excise or other similar tax applicable to goods or services provided by Seller to Buyer shall be added to the purchase price and shall be paid by Buyer unless Buyer provides Seller with evidence satisfactory to Seller of an exemption from such taxes. When Seller is required by law or regulation to collect such taxes, Seller will add such taxes to the purchase price of the goods or services.

7. Payment Terms. Buyer shall pay all invoices in a timely manner and in accordance with the provisions of the invoices. Any invoiced amount which is not paid when due may bear interest at the rate of one and one-half percent (1-1/2%) per month or the highest rate then permitted by law, whichever is less, until paid in full. Seller reserves the right to exercise any of its lawful remedies if Buyer does not make payments when due. Buyer shall promptly reimburse Seller for all costs and expenses, including reasonable attorneys’ fees, incurred by Seller in collecting sums due it under this Document or pursuant to any invoice. If a down payment by Buyer is required by Seller as specified in the applicable purchasing documents, Buyer acknowledges that Seller is not required to commence performance, manufacture or delivery of the Products being purchased by Buyer until such down payment in good funds has been received by Seller. If payment is required to be by international letter of credit, the letter of credit and its provisions must be acceptable to Seller.

8. Buyer’s Financial Condition. This Document and all shipments made pursuant to this Document shall at all times be subject to the approval by Seller of Buyer’s financial condition. If the financial condition of Buyer at any time becomes unsatisfactory to Seller in Seller’s sole discretion, or if Buyer fails to make any payment when due, then in addition to any other rights Seller may have, Seller may defer or decline to continue performance or make any shipment or shipments of Products or may condition any such performance or shipment upon receipt of satisfactory security or cash payments in advance.



9. Security Interest. Buyer grants to Seller and Seller retains a full security interest in all Products and all proceeds and products thereof until all amounts due or to become due to Seller have been paid. Any repossession and removal of Products shall be without prejudice to any of Seller's other remedies at law or in equity. Buyer agrees, at any time and without further consideration, to do or cause to be done, executed and delivered, all such further acts and instruments (including without limitation financing statements appropriate for filing) as Seller may reasonably request in order to perfect Seller's security interest.

10. Cancellation. No purchase order nor any release under this Document is subject to cancellation by Buyer except upon (a) written request of Buyer and (b) written approval of Seller. Since the Products are customized products specifically manufactured for each customer, Seller has the absolute right in its discretion to deny Buyer's cancellation request. Because Seller's expenses related to canceling firm orders are dependent, in part, upon (i) Seller's inventory carrying costs, (ii) the likelihood of Seller quickly selling the subject Products to other buyers, (iii) Seller's other related out-of-pocket costs, (iv) the percentage of completion at the time of requested cancellation and (v) administrative costs, Seller may charge Buyer a cancellation fee. If Seller permits the cancellation of the purchase order for the Products, Buyer agrees to pay Seller for all of Seller's out-of-pocket costs associated with the cancellation of the order including, but not limited to: (i) raw materials, (ii) work in process, (iii) inventory carrying costs, (iv) scrapping and disposal fees, (v) engineering and labor and (vi) a reasonable and equitable profit for Seller, which shall not be less than twenty-five percent (25%) of the original quoted gross sales price for the cancelled Products. In no case will the cancellation charge be less than Seller's actual costs (including overhead and other indirect costs). The amount of cancellation charge to be charged to Buyer shall be determined at the sole discretion of Seller and may equal 100% of the amount of the order at the time of Seller's receipt of Buyer's request for cancellation. Buyer is entitled to receive a written notice from Seller setting forth how the cancellation charge was calculated. Upon payment of the cancellation charge, Buyer shall be entitled to receive all raw materials and work in process, and Seller agrees to ship such goods to Buyer at Buyer's expense. Seller also reserves the right, by written notice to Buyer, to cancel any order, without liability to Seller, in the event of the happening of any of the following: insolvency of Buyer, the filing of a voluntary petition in bankruptcy by Buyer, the filing of an involuntary petition to have Buyer declared bankrupt, the appointment of a receiver or trustee for Buyer, the execution by Buyer of an assignment for the benefit of creditors, the discontinuance of business by Buyer, or the sale by Buyer of the bulk of its assets other than in the usual course of business.

11. Proprietary Information. "Proprietary Information" includes any information, material or apparatus, of a confidential or proprietary nature obtained from Seller and any information obtained from Seller which is not readily available to Seller's competitors and which, if known by a competitor of Seller, might lessen any competitive advantage of Seller or give such competitor a competitive advantage. Seller retains ownership of all Proprietary Information, whether written, oral, electronic, visual, graphic, photographic, observational or otherwise, and all documentation which contains Proprietary Information. Buyer shall not disclose, duplicate or reproduce any Proprietary Information, in whole or in part, nor shall Buyer use any Proprietary Information other than in the course of performing its obligations to Seller or in connection with the usage of the Products purchased from Seller. Buyer shall take all reasonable steps to prevent the disclosure, duplication or reproduction of any Proprietary Information. Buyer shall limit access to the Proprietary Information to those employees of Buyer with a valid need to know. Notwithstanding the foregoing, Buyer shall not be required to refrain from disclosing or using any Proprietary Information which has become known to Buyer if the original source of such Proprietary Information was not Seller or any person or party affiliated with Seller or having a relationship of confidentiality with or an obligation of confidentiality to Seller. Seller shall have no obligation to provide detailed drawings or design information for the Products to Buyer. Proprietary Information shall not, however, include any information which Buyer can establish: (i) is now, or hereafter becomes, through no act or failure to act on the part of Buyer, generally known or available in the public domain; (ii) Buyer can demonstrate was rightfully in its possession or previously known to Buyer prior to its disclosure to Buyer by Seller; (iii) is obtained by Buyer from a third party without a breach of any obligation to Seller or (iv) is independently developed by Buyer without use of or reference to Seller's Proprietary Information

12. No License. Neither this Document nor purchase of any Products shall be construed to confer upon Buyer or its customers any license under any patent or other proprietary rights of Seller, except the right to use such goods for the purposes for which they are sold. Tooling, set-up, fitting-up, drawings, design information, non-recurring engineering, and partial preparation charges when invoiced cover only part of the cost thereof to Seller. Buyer does not acquire any right, title or interest in any tooling, set-up, fitting-up, drawings, design information, or invention or other intellectual property resulting therefrom, which remain the sole property of Seller.

13. Property Furnished by Buyer. If Buyer furnishes any components, tools, dies, jigs or other property, equipment, material or facilities to Seller in connection with the design or construction of the Product, Buyer shall bear all risk of loss or damage with respect to such property, equipment, material or facilities and shall indemnify and hold Seller harmless from and against all loss, cost, expense or liability arising in connection with such property, equipment, material or facilities. Seller shall not be responsible for any delay in performance or nonperformance or the failure of the Product to conform to applicable specifications resulting, in whole or in part, from Seller's use of property, equipment, material or facilities furnished by Buyer.

14. Changes. Buyer requested changes to purchase orders for additions or modifications must be submitted in writing for review and approval by Seller, which approval is at the reasonable discretion of Seller and may be conditioned upon the payment of additional fees and charges. Seller reserves the right to make changes without notice in the design, construction, arrangement, components or equipment if such changes, in its sole judgment and discretion, constitute improvements over the original specifications.

15. Limited Warranty.

(a) Except as otherwise stated in this Document or in an order acknowledgment delivered to Buyer, Seller warrants to Buyer that the Products (other than tooling) (i) shall be free of defects in materials and workmanship and shall have a warranty period for either twelve (12) months from date of commissioning, a maximum 2000 production hours or fifteen (15) calendar months after shipment, whichever comes first; and (ii) shall be free of liens and encumbrances when shipped to Buyer other than for the permitted security interest in favor of the Seller pursuant to paragraph no. 9 above. Seller's warranties will not apply to any Product with respect to which there has been (i) improper installation or testing by Buyer, (ii) failure of Buyer to provide a suitable operating environment, (iii) use of the Product by Buyer for purposes other than that for which it was designed, (iv) failure by Buyer to monitor or operate the Product in accordance with applicable Seller specifications and good industry practice, (v) unauthorized attachment or removal or alteration of any part of the Product by Buyer, (vi) unusual mechanical, physical or electrical stress of Product by Buyer, (vii) modifications or repairs to Product done by other than Seller, including, in particular, any modifications to the hydraulic, pneumatic, electric, electromechanical or computer driven process controls as these machine systems are constructed to operate within Buyer supplied and approved specifications, (viii) mishandling during shipment of the Product by Buyer; (ix) failure by Buyer to properly maintain the Product, which Buyer acknowledges is essential to the proper functioning of the Product and Buyer expressly agrees to properly maintain the Product, (x) failure of Buyer to have the Product operated by qualified personnel, with Buyer acknowledging that it has the sole responsibility for having the Product operated by qualified personnel and that operation of the Product requires a high level of expertise and experience or (xi) any other abuse, misuse, neglect or accident of the Product. In no circumstance shall Seller have any liability or obligation with respect



to expenses, liabilities or losses associated with the installation or removal of any Product or the installation or removal of any components for inspection, testing or redesign occasioned by any defect or by repair or replacement of a Product.

(b) Buyer shall notify Seller in writing promptly (and in no case later than thirty (30) calendar days after discovery) of the failure of any Product to conform to the warranty set forth above, shall describe in commercially reasonable detail in such notice the symptoms associated with such failure, and shall provide to Seller the opportunity to inspect such Product as installed, if possible. The notice must be received by Seller during the Warranty Period for such Product. Unless otherwise directed in writing by Seller, within thirty (30) calendar days after submitting such notice, Buyer shall package the allegedly defective Product in its original shipping carton(s) or a functional equivalent and shall ship it to Seller.

(c) Within a reasonable time after receipt of the allegedly defective Product and verification by Seller that the Product fails to meet the warranty set forth above, Seller shall correct such failure by, at Seller's option, either (i) modifying or repairing the Product or (ii) replacing the Product. Such modification, repair or replacement and the return shipment of the Products with minimum insurance to Buyer shall be at Seller's expense. Buyer shall bear the risk of loss or damage in transit, and may insure the Product. Buyer shall reimburse Seller for transportation costs incurred for the Product returned but found by Seller not to be defective. Modification or repair of the Product may, at Seller's option, take place either at Seller's facilities or at Buyer's premises. If Seller is unable to modify, repair or replace the Product to conform to the warranty set forth above, then Seller shall, at Seller's option, either refund to Buyer or credit to Buyer's account the purchase price of the Product.

THESE REMEDIES SHALL BE BUYER'S EXCLUSIVE REMEDIES FOR BREACH OF WARRANTY.

(d) EXCEPT FOR THE EXPRESS WARRANTY SET FORTH ABOVE, SELLER MAKES NO OTHER REPRESENTATIONS, WARRANTIES OR CONDITIONS, EXPRESS OR IMPLIED, STATUTORY OR OTHERWISE, REGARDING THE PRODUCTS, THEIR FITNESS FOR ANY PURPOSE, THEIR QUALITY, THEIR MERCHANTABILITY, THEIR NONINFRINGEMENT, OR OTHERWISE. NO EMPLOYEE OF SELLER OR ANY OTHER PARTY IS AUTHORIZED TO MAKE ANY OTHER REPRESENTATIONS, WARRANTIES, OR CONDITIONS FOR THE PRODUCTS OTHER THAN THE WARRANTY SET FORTH ABOVE. SELLER'S LIABILITY UNDER THE WARRANTY SHALL BE LIMITED TO A REFUND OF THE PURCHASE PRICE OF THE PRODUCT. IN NO EVENT SHALL SELLER BE LIABLE FOR THE COST OF PROCUREMENT OR INSTALLATION OF SUBSTITUTE GOODS BY BUYER OR FOR ANY SPECIAL, CONSEQUENTIAL, INDIRECT OR INCIDENTAL DAMAGES.

(e) Buyer assumes the risk and agrees to indemnify Seller against and hold Seller harmless from all liability relating to (i) assessing the suitability for Buyer's intended use of the Products and of any system design or drawing and (ii) determining the compliance of Buyer's use of the Products with applicable laws, regulations, codes and standards.

(f) The Seller will not assume any liability for any expenses incurred by Buyer in repairing or correcting defects without Seller's prior written authorization.

(h) Seller's warranties do not extend to or include items (including items incorporated into the Products) which are not manufactured by Seller but will upon Buyer's request, provide Buyer with a copy of any warranty furnished by the manufacturer of such items

(i) Seller provides no warranties or guarantees that (i) any Buyer supplied tooling will be suitable for mounting on the Products and satisfying intended use; (ii) the material to be spun on Seller's Products will produce the intended parts as proper selection of the material to be spun is solely the responsibility of Buyer; (iii) any tooling concept, design or Seller provided tooling (e.g., spin rollers, mandrels, spindle adapters, tailstock following devices, centering devices, mechanisms for trimming, machining and flanging and material support units) will produce the parts intended by Buyer; (iv) Buyer's manufacturing process will be successful in producing the intended parts, as Buyer acknowledges that metal spinning is a very complex and delicate process involving significant technical expertise and experience; (v) the Products' cycle times will satisfy any anticipated or desired cycle times; and (vi) the Products will function identically or substantially identical in any manner to Products made by other manufacturers, as Buyer acknowledges that the Products are custom designed products based in part on Buyer's input into the design process of the Products.

(j) SELLER'S OBLIGATION TO HONOR THE ABOVE WARRANTY IS CONTINGENT UPON SELLER'S RECEIPT OF PAYMENT IN FULL FOR THE PRODUCTS ENTITLED TO THIS WARRANTY.

16. Limitation of Liability and Indemnity. Notwithstanding any other provision in this Document or in any other document or communication, (a) Seller's liability and obligations with respect to any claim(s) resulting or arising from or relating to this Document or the Products, whether in contract, strict liability, tort or otherwise, and even if Buyer's exclusive remedy fails of its essential purpose, shall in no event exceed in the aggregate the total purchase price received by Seller for the Products (or, in the case of obligations arising from or relating to particular Products or services rendered in connection herewith, the purchase price of such Products or amount received by Seller for such services, respectively), and (b) Seller shall in no event be liable to Buyer or any other person or entity, whether in contract, strict liability, tort or otherwise, for special, indirect or consequential damages of any kind whatsoever, or claims of any third parties. By accepting delivery of the Products ordered, Buyer agrees that it indemnifies and holds harmless Seller from and against all claims, loss, damage and liability, including without limitation for personal injury, property damage or commercial loss of whatever kind, directly or indirectly arising from or relating to the hazards inherent in Buyer's facilities or activities. No action or claim against Seller pursuant to the terms and conditions set forth in this Document and any accompanying purchase order or any obligation of Seller herein can be commenced after more than a year after the occurrence of the events giving rise to the action or claim.

17. Protective Guards. Buyer is responsible for all protective guards where Products are operating. Buyer accepts responsibility for interpreting local, state and federal regulations regarding protective guards, and installation and consistent use of guards wherever deemed necessary. Buyer indemnifies Seller for all liability arising from the use of the Products without adequate protective guards. Buyer also is solely responsible for the safe operation of the Products.

18. Seller's Programming Software/Teach and Play/Siemens CNC System. Seller does not actively promote, provide training, nor make any warranty for, or guarantee the CNC system for operational features and functions beyond the scope of Buyer's intended use in a metal spinning application or equipment.



19. **Buyer Supplied Tooling Specifications.** All mandrel tooling is to be made of steel and should have a total indicated runout (TIR) of less than or equal to 0.003". No plastic or wood tooling will be used for machine acceptance. Threaded tooling adapters must have a provision for installing an anti-rotation locking mechanism to prevent mandrel spin-off. Any modifications or extra adapters needed to be made to the mounting to accommodate Buyer-supplied tooling will be charged at Seller's normal time and material rates.

20. **Non-Waiver of Default.** No failure by Seller to insist on strict performance of any term or condition hereof shall constitute a waiver of such term or condition or any breach thereof, nor shall such failure in any way affect Seller's legal remedies with respect to any default by Buyer hereunder.

21. **Force Majeure.** Seller shall not be liable for any failure or delay in manufacture or delivery resulting from any cause beyond the reasonable control of Seller, including by way of illustration and not by way of limitation, compliance by Seller with any government or military regulation, or from acts of God, fires, or other casualty or accident, strikes, lockouts, factory shutdowns, or alterations, embargoes, riots or other disorders, delays or shortages in transportation, or inability to obtain sufficient quantity of fuel, power, labor, manufacturing facilities of materials or other supplies from the usual sources of Seller. Neither shall the Seller be held to the price of the Products in its quotations or order acknowledgements, in the event cost of materials needed for the Seller's manufacturing process of the Products, as the result of events listed in this paragraph, and being beyond the reasonable control of the Seller, would increase beyond what can normally be expected during the life of the contract. Should such cost increases occur, the Seller and the Buyer agree to re-negotiate the price for the Products based on the actual cost increases to the Seller for the Products as a result of such price increases of materials used in the manufacturing of the Products in question.

22. **Arbitration.** Any controversy or dispute arising out of this Document or the transactions described or referred to in this Document, the interpretation of any of the provisions of this Document, or the action or inaction of any party shall be submitted to arbitration in Orange County, California, under the applicable rules of the American Arbitration Association. All statutes of limitations or any waivers contained in this Document which would otherwise be applicable shall apply to any arbitration proceeding under this Document. The arbitrator's authority to grant remedies shall be limited to those remedies that could be granted or awarded by a judge of the Superior Court of the State of California applying California law to the claims asserted. The arbitrator shall prepare a written decision for the award, including factual findings and the reasons that form the basis of the arbitrator's decision. The arbitration decision shall be mailed to the parties no later than thirty (30) days after the close of the arbitration hearing. The arbitrator shall not have the power to commit errors of law, and the award of the arbitrator shall be vacated or corrected for any such error. Judgment upon the award rendered may be entered in any court having jurisdiction.

23. **Governing Law.** This Document and the transactions described or referred to in this Document shall be governed by and construed in accordance with the substantive laws of the State of California without giving effect to the rules of conflicts of law. Venue of any action arising out of or in connection with this agreement shall be Orange County, California.

