

CONTURA G2

Measuring Center



1. Selection of Installation Site and Installation Conditions

When selecting the installation site, please make sure that the following conditions either already exist or can be implemented there.

The system comprises the following components:

1. Coordinate measuring machine
2. Controller
3. Control console
4. Data station (peripherals)

1.1 Required Room Height

This dimension equals the sum of the height of the coordinate measuring machine and a minimum overhead clearance of 200 mm.

Example: Contura G2

Height of CMM	2800 mm
Minimum installation clearance	200 mm
Required minimum room height above floor or foundation	3000 mm

1.2 Required Floor Surface

A cutout layout plan is included in this brochure to give you a quick overview of the required floor surface. When preparing the space assignment plan, make sure that your CMM is well accessible from all sides.

Please select the installation site so that there is a distance of at least 800 mm between the CMM and the wall.

1.3 Transport Lanes

Please check the ground-floor and upper-storey floor loading capacity of all transport lanes leading to the installation site. The doorways must be at least 5 cm wider and higher than the largest packaged unit, including the transport vehicle. The dimensions and weights of the transport units are specified in this brochure.

1.4 Ambient Conditions

Bridge-type coordinate measuring machines are high-tech products. Their specified quality is attainable only if you ensure that the following conditions are met.

Permissible Storage Temperature Range

5°C to 40°C

Pay special attention to the storage temperature during winter. Avoid storing at temperatures below 5°C.

Ambient Conditions for Operational Readiness

Permissible ambient temperature: +17°C to +35°C

Permissible air humidity:

40% - 60% without condensation

Sound level at installation site: <90dB

Max. altitude above sea level:

for 100 - 125 V 3000 m

for 220 - 240 V 2000 m

Temperature Conditions for Operation of CMM:

The measuring uncertainty specified for your CMM can be guaranteed if:

1. you use a measurement correction program and enter the workpiece and CMM temperatures as well as the temperature expansion coefficients of the workpiece material.
2. the following temperature conditions are observed:

CMM Type	Temp. Range (°C)	Temperature Gradient		
		per hour (°K/h)	per day (°K/d)	per m (°K/m)
CONTURA G2	18 - 22	1.0	1.5	1.0
CONTURA G2 HTG (optional)	18 - 26	1.0	1.5	1.0

Please make sure that sufficient lighting is available.



The use of sources of heat near the CMM must be avoided wherever possible.

1.5 General Protective Measures

The CMM must be protected against dirt and foreign particles (e.g. casting sand, metal filings and bore chips, oil, coolants, lubricants and soot). Deposits of materials such as casting sand and swarf may lead to increased expenses for cleaning and maintenance.



1.6 Vibrations at the Installation Site

The following diagram(s) show(s) the permissible floor vibrations.

Vibrations are often caused by heavy processing machinery, transport vehicles (cranes or stackers) and stamping or forging machines located in adjacent rooms.

A measurement is required to determine the actual magnitude of local floor vibrations.

You can order such a vibration analysis from Carl Zeiss Oberkochen, phone: +49-(0)7364-206168.

In any case, the results must be made available to CZO for evaluation.

1.7 Floor Load

When calculating or planning any floor reinforcement (foundation etc.) which may be required, it is advisable to consult a statics engineer who is familiar with your local floor conditions. To determine the floor load exerted by the CMM, see the pertaining information in this brochure.

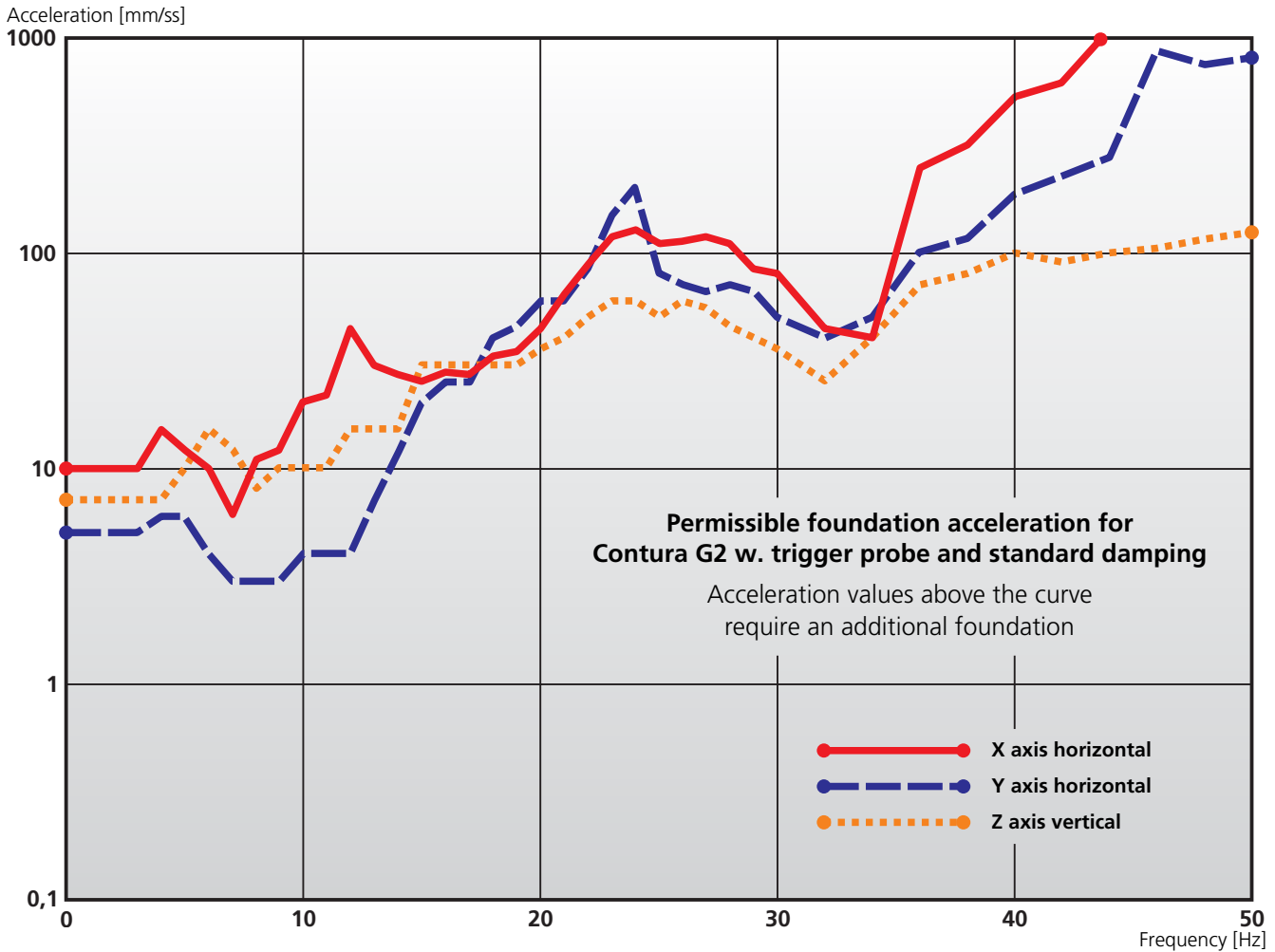

Acceleration [mm/ss]

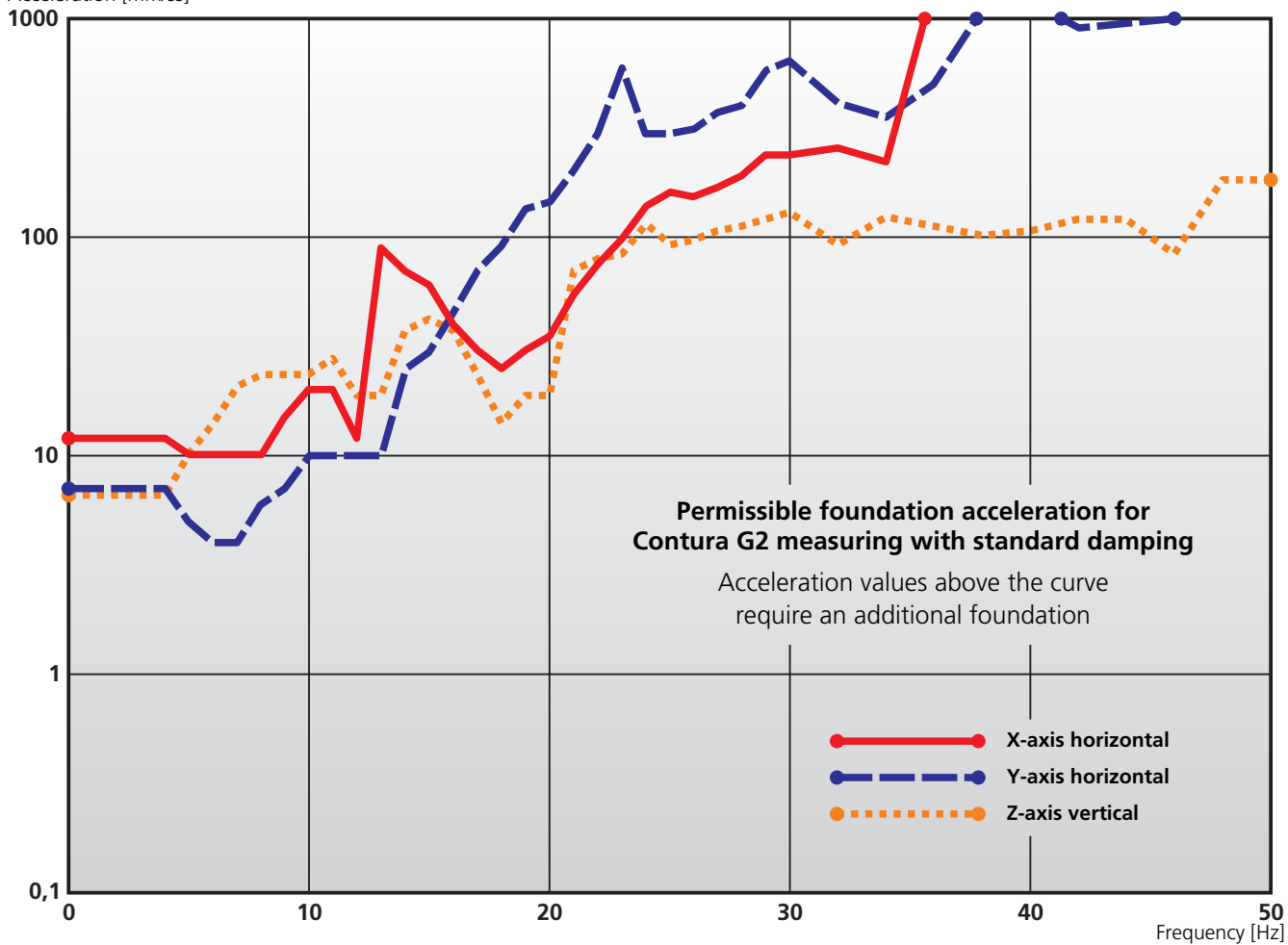

2. Preparations for Installation / Electric Power Supply

Please make sure that the following preparations are made by the date of installation:

2.1 Preparing the Floor Surface

The floor surface must be clean and the unevenness of the bearing surfaces must not exceed max. 25 mm.

2.2 Electric Power Supply

We recommend connecting the system to a power source which does not supply electricity to peak-load or high-consumption equipment (elevators, air conditioning systems). Due to the possibility of negative influences, avoid installing the CMM near

- **High-consumption equipment** (e.g. welding machines)
- **High-interference (EMI) equipment** (e.g. electron discharge machines).

The use of mobile telephones or walkie talkies within a radius of 3m surrounding the CMM is also prohibited. This precaution is necessary to prevent malfunctions, **especially in connection with data processing systems.**

A permanent connection (max. 16A) must be provided for the system. Alternatively, a 3-wire CEE-form plug connection is also acceptable. A 5-plug multiplex outlet must be provided by you (the customer) for the data station. We recommend the on-site installation of a surge arrester, e.g. Phoenix Flashtab FLT 25-400, as basic protection against surge voltage.

We recommend making the connection as shown in the following drawing, **taking into account that all pertaining national regulations also must be observed.**

2.3 Electric Power Supply Parameters

To ensure trouble-free data transmission between the CMM and the data station, the line power supply must

comply with the following specifications.

Line power supply:

- **Line voltage:**
1/N/PE 100/110/115/120/125/230/240 VAC
- **Max. voltage fluctuations:** $\pm 10\%$
- **Frequency:** 50 or 60 Hz
- **Max. frequency fluctuations:** $\pm 3.5\%$
- **Max. power sag:** 10 ms
(Max. one half-wave may be missing at 50 Hz)
- **Interference peaks**
Max. rise time at 5 ns: $\pm 500\text{ V}$
Max. rise time at 50 μs : $\pm 1000\text{ V}$

Max. amount of heat generated:

3600 kJ/h

Max. total power requirement:

CMM: max. 1000 VA

Peripheral workstation: max. 1000 VA

2.4 EMC

EN 61326-1 Appendix A, Class A

Warning !

This is a class A device, and may therefore cause radio interference in the surrounding area. In such cases, the operator may be required to take appropriate action and bear any costs thus incurred.

2.5 Stabilizing the Line Voltage

If out-of-tolerance r.m.s. fluctuations of the nominal voltage briefly occur, a line analysis must be performed. Please contact us if you have such a requirement. We will be glad to advise you and suggest suitable measures. In most cases, it is sufficient to install a separate stub cable from the main distributor to the CMM.

Connection diagram

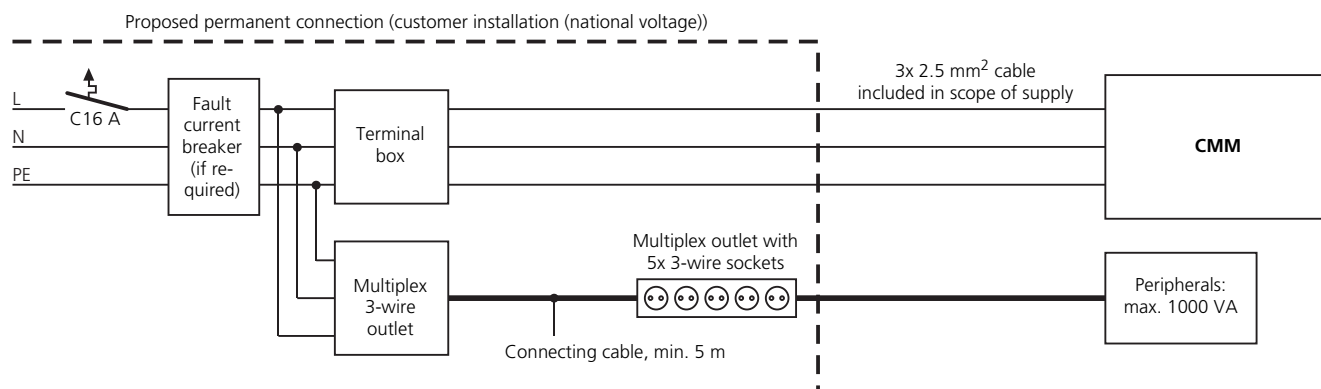

2.6 Machine Parameters

- **Overvoltage category:** III
- **Pollution degree:** 2
- **Protection class:** 1

2.7 Teleservice

You will require an Internet connection for Teleservice. For more details, please refer to the "**Teleservice**" brochure.

2.8 Compressed Air Supply

Please make sure that the air pressure required to operate your CMM is available as described below:

- Minimum pressure 6bar, max. pressure 10bar.
- Prefiltered air; completely free of contaminating particles, oil vapors and water residues.
- Air quality in compliance with ISO 8573 Part 1 Classification 4, which includes:
 - Par. 6.1: Max. particle size 15µm, max. dirt particle concentration 8mg/m³
 - Par. 6.2: Max. compressed air dew point +3°C
 - Par. 6.3: Max. oil concentration of 5mg/m³

If the above air quality is not attained, it may be necessary to add an additional downstream air filtration unit and, in some cases, a membrane dryer to the compressed air line of the CMM. These units can be ordered from CZ. Please ask your contact person for more information.



Failure to comply with the above air quality specifications could result in damage not covered by your warranty.

Note!

Air consumption of CMM:

Max. 30 l/min at 5 bar (150 normal liters/min at 1 bar)

Connection point for CMM air supply

Our technician requires a connection point to hook up your CMM to the compressed air supply. This point must be provided by you as shown in the section entitled "**CMM Installation Dimensions and Arrangement of the Steel Plates**". The connection provided at the CMM end must fit air hoses with an external diameter of 10mm. The supply line from your main connection to the CMM connection point will be laid during installation of the CMM.

When laying this connection up to the CMM, please make sure that the connection point is readily accessible and is not blocked by the base of the CMM. The compressed-air tube must be laid protected.

2.9 Transport Vehicles

Please provide a forklift with sufficient carrying capacity and fork length to unload the packaged units and transport them to the storage or installation site. The loading capacities required of these vehicles are specified on the following pages.

All transport lanes and approaches should be kept open during the entire installation and startup period to help ensure trouble-free installation.

The transport locks and braces on the CMM, pallet (*shipping crate*) and lashing straps must be returned to CZ.



Packing materials such as e.g. foils or styrofoam chips ("popcorn") are recycled by Carl Zeiss and should be returned to CZ along with the transport stops and braces if they are clean and no dirt has been mixed in with them.

Note!

2.10 Unloading/Storing/Unpacking

With outdoor temperatures below 0°C, CMM assemblies with granite guideways are not enclosed in a protective PVC bag, but sealed air-tight along with a drying agent in an aluminum-coated foil (insulated packaging).

Unloading and transport must be performed only with transport lugs or pallets. **Be careful not to damage the insulated packaging!** Please remember that your CMM is a valuable, high-precision instrument. For this reason, you should avoid jolting or knocking the crate at all times.

Please leave the crates packed and store them in a sheltered location as close as possible to the installation site.

Adaptation to room temperature:

Store the crates in a room with a minimum ambient temperature of 15° C at least 2 days before our system specialist arrives. The crates may be unpacked and the insulated packaging may be removed only by our system specialist! Please also make sure that a place suitable for depositing the empty containers is provided.

2.11 Moving the CMM to another location



A system specialist should always be present when moving the CMM to another location as a precaution to ensure that it is not damaged.



3. Shipping Crates and Pallets

3.1 Dimensions and Weights



The machine components are delivered on transport pallets with insulated packaging. They are delivered in a shipping crate only for air cargo and overseas shipments.

Note!

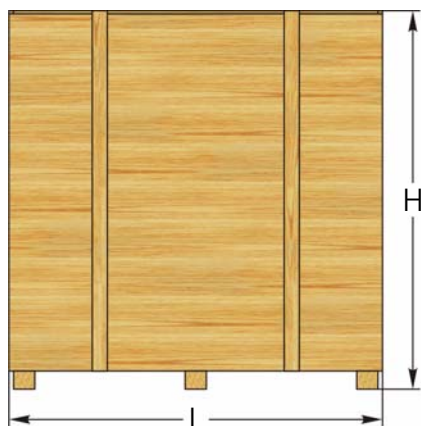

Shipping crate for	Crate dimensions in mm (max.)			m ³	Max. tare wt. (kg)		Max. gross wt. (kg)	
	L	W	H		Sea/air cargo crate	Truck pallet	w. sea/air cargo crate	with truck pallet
CONTURA G2								
X=700, Y=700, Z=600	2168	1943	2499	10.6	610	320	1890	1600
X=700, Y=1000, Z=600	2468	1943	2499	12.0	620	420	2170	1970
X=1000, Y=1200, Z=600	2668	2253	2524	15.2	890	560	3200	2870
X=1000, Y=1600, Z=600	3068	2253	2524	17.5	1190	840	4000	3650
X=1000, Y=2100, Z=600	3568	2253	2524	20.3	--	1190	--	6500
CONTURA G2 (opt. granite U-profile)								
X=1000, Y=1200, Z=600	2668	2253	2730	16.4	--	560	--	3490
X=1000, Y=1600, Z=600	3068	2253	2730	18.9	--	840	--	3960
X=1000, Y=2100, Z=600	3568	2253	2730	22.0	--	1190	--	6950
Pal box with computer table							40	
Pal box with computer unit							205	70
Controller	1100	1100	1100	1.4	90		227	

Note: All values specified above are maximum values. Any values not entered were not available at the time of printing. For **technical reasons** the dimensions of the shipping crates (L, W and H) may deviate from the values specified here **by as much as +50 mm**.



4. CMM Installation Dimensions and Arrangement of Steel Plates

4.1 Installation Dimensions for CONTURA G2 (all dimensions in mm, scale 1:30)

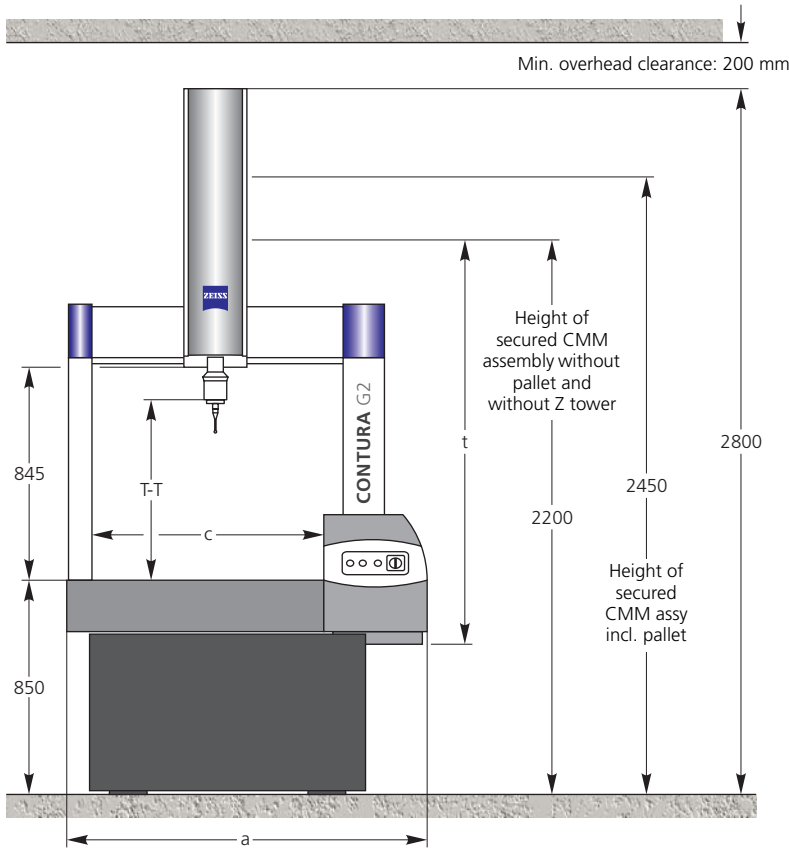

CONTURA G2

X/Y/Z measuring range	Net weight of CMM	Max. permissible workpiece weight
700/700/600	ca. 1280 kg	560 kg
700/1000/600	ca. 1550 kg	730 kg
1000/1200/600	ca. 2310 kg	1150 kg
1000/1600/600	ca. 2810 kg	1500 kg
1000/2100/600	ca. 5310 kg	1814 kg

T-T = Distance between table and bottom of probe	
VAST _{XT} probe	716
RDS probe	665

CONTURA G2

X/Y/Z measuring range	Length - a -	Length - b -	Length - c -	Length - t -
700/700/600	1430	1525	920	1603
700/1000/600	1430	1830		
1000/1200/600	1743	2030	1225	1756
1000/1600/600	1743	2430		
1000/2100/600	1743	2945		

- ① = On-site air supply connection, precleaned compressed air supply with pressure of 6-10 bar.
- ② = Power supply (two outlets with max. 16 A) to be installed by the customer.
- ③ = Telephone connection (ISDN)
- ④ = CMM compressed air supply connection
- ⑤ = CMM ↔ control connecting cable
- t = Transport height without base

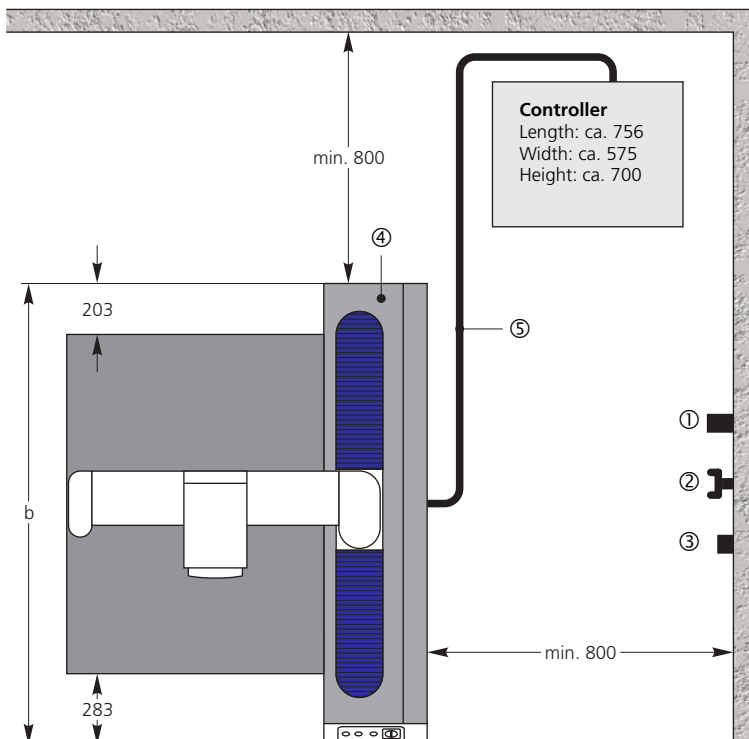

CONTURA G2

X/Y/Z measuring range	Max. cable leng. CMM ↔ control ⑤
700/700/600	ca. 3700 mm
700/1000/600	ca. 3550 mm
1000/1200/600	ca. 6300 mm
1000/1600/600	ca. 6000 mm
1000/2100/600	ca. 5700 mm



4.2 Installation Dimensions for CONTURA G2 with opt. U-profile (all dimensions in mm, scale 1:30)

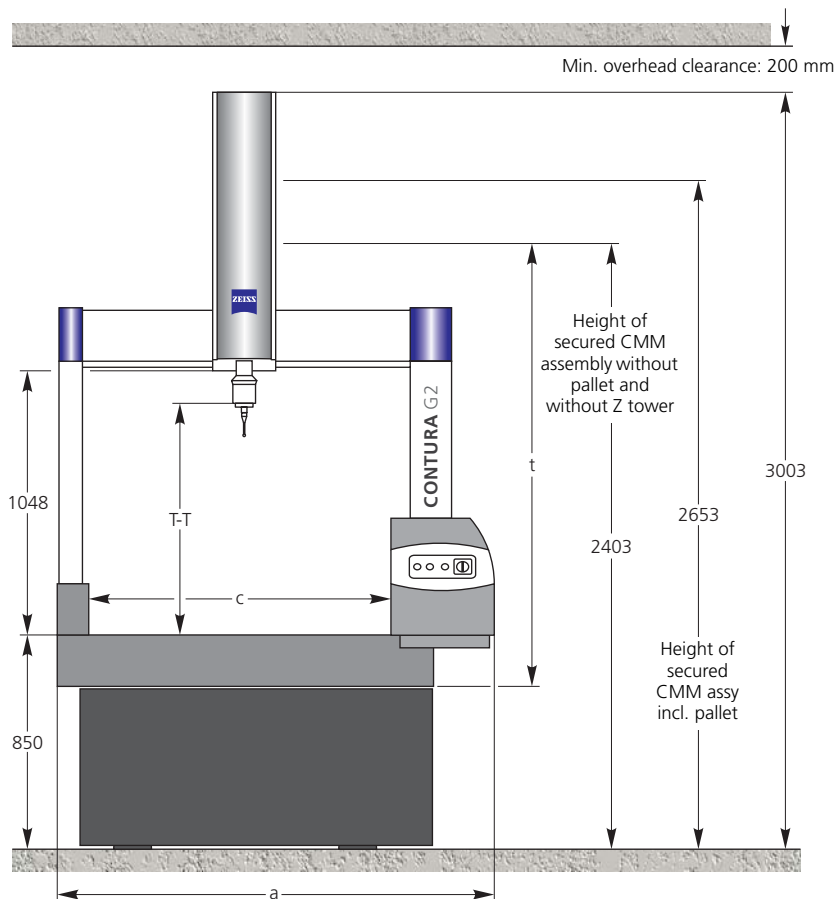

CONTURA G2 with optional U-profile

X/Y/Z Measuring range	Net weight of CMM	Max. permissible workpiece weight
1000/1200/600	ca. 2583 kg	1150 kg
1000/1600/600	ca. 3163 kg	1500 kg
1000/2100/600	ca. 5755 kg	1814 kg

T-T = distance betw. table and lower edge of probe	
VAST _{XT} probe	919
RDS probe	868

CONTURA G2 with optional U-profile

X/Y/Z Measuring range	Length - a -	Length - b -	Length - c -	Length - t -
1000/1200/600	1743	2030	1200	1806
1000/1600/600	1743	2430		1959
1000/2100/600	1743	2945		

- ① = On-site air supply connection, precleaned compressed air supply with pressure of 6-10 bar.
- ② = Power supply (two outlets with max. 16 A) to be installed by the customer.
- ③ = Telephone connection (ISDN)
- ④ = CMM compressed air supply connection
- ⑤ = CMM ↔ control connecting cable
- t = Transport height without base

CONTURA G2

X/Y/Z Measuring range	Max. cable leng. CMM ↔ control ⑤
1000/1200/600	ca. 6300 mm
1000/1600/600	ca. 6000 mm
1000/2100/600	ca. 5700 mm

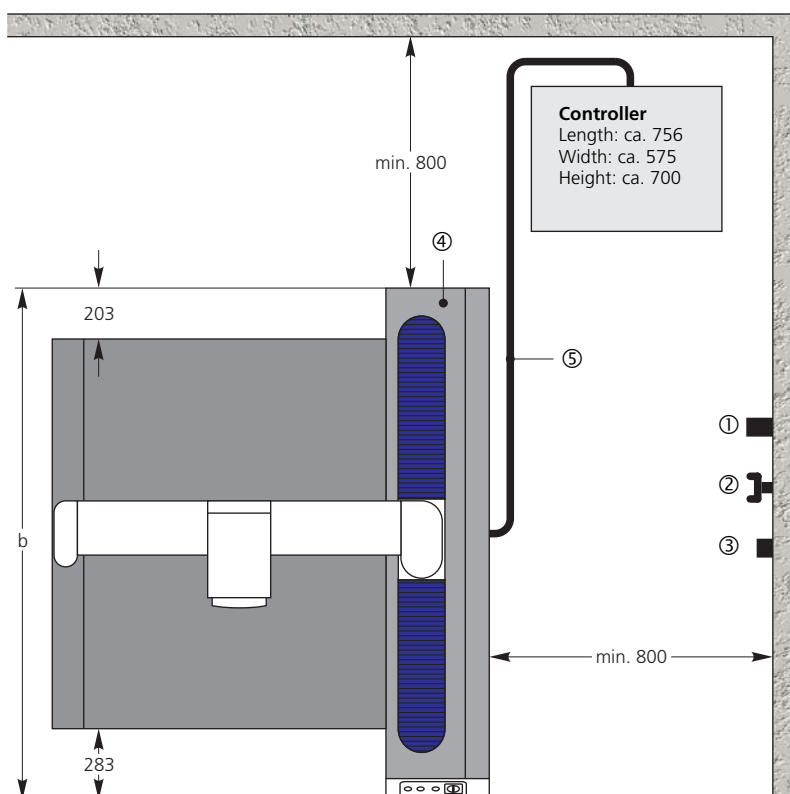

4.3 Installation of Floor Stripe or Chain

The dangers posed by the CMM are impossible - or at least difficult - for untrained personnel to recognize. For this reason, a restricted-access zone must be set up around the machine to prevent damage or injury caused by untrained personnel.

The entrance to this area should be clearly marked by a warning sign reading:

"Admittance only for authorized personnel"

and may be entered only by persons who have received proper training (operators).

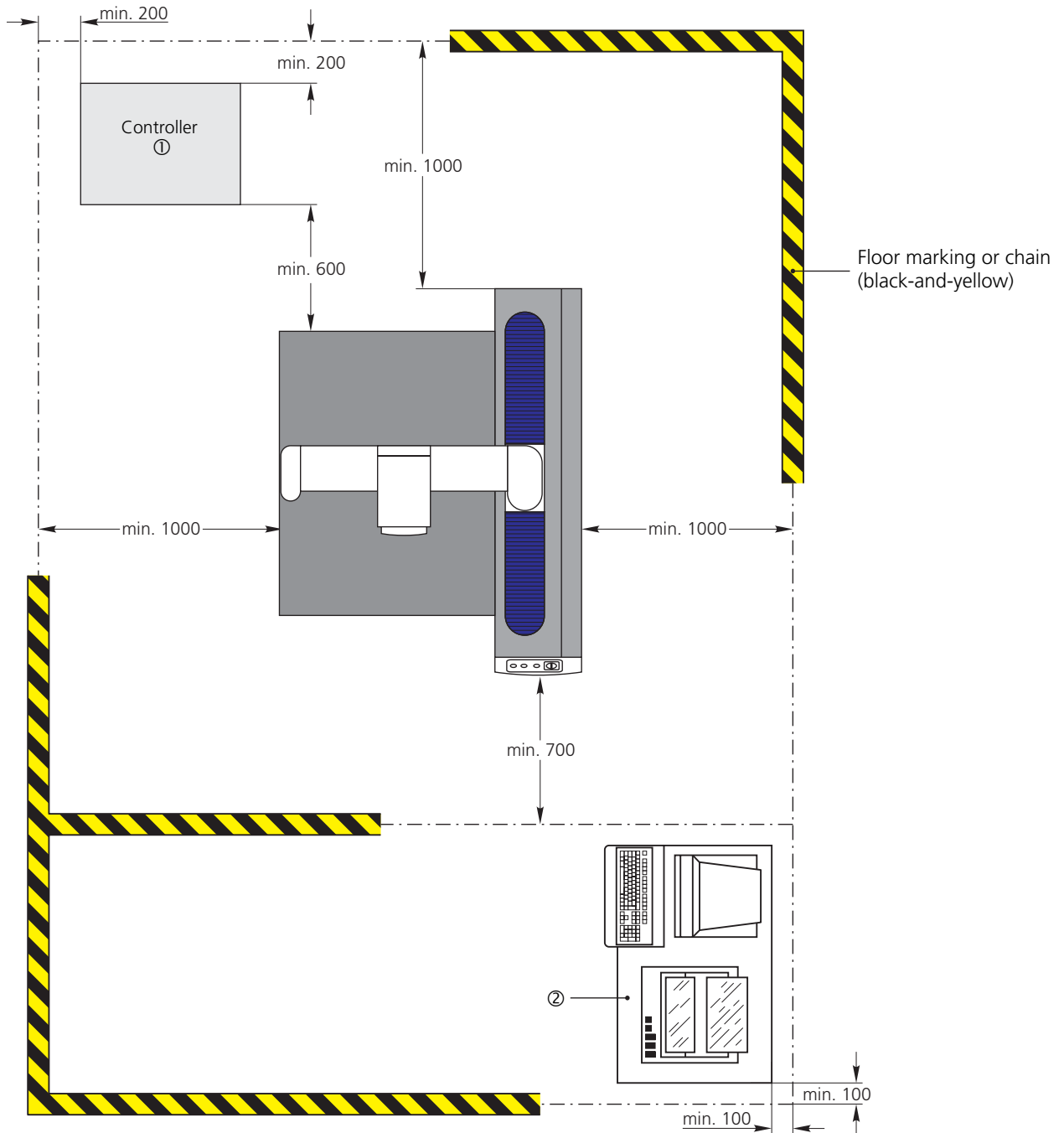

Note! ① The back door of the controller cabinet must be located at least 200mm away from the wall. Moreover, the air exchange with the surrounding environment should not be blocked. The control cabinet should be placed so that the rear side of the controller always faces away from the CMM.

② CMM table (optional) with computer and printer



4.4 Arrangement of the Steel Plates for Contura G2

The relative unevenness of the bearing surfaces must not exceed max. 25mm (1").

The deviation tolerance for the center-to-center plate distance is (A) ± 10 mm (all dimensions in mm)

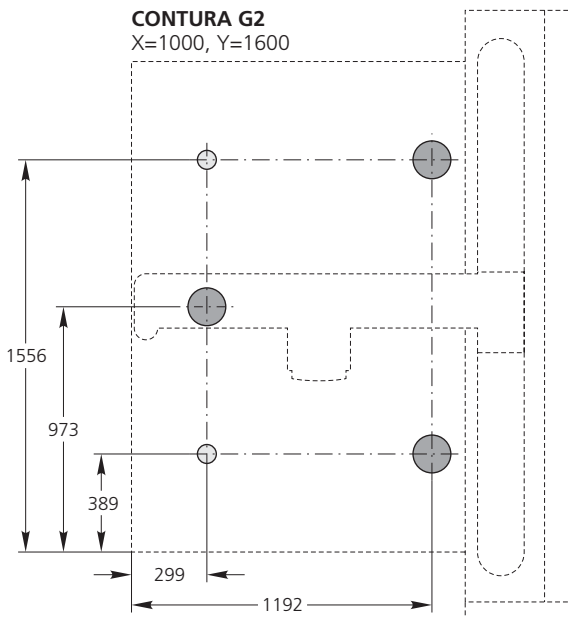
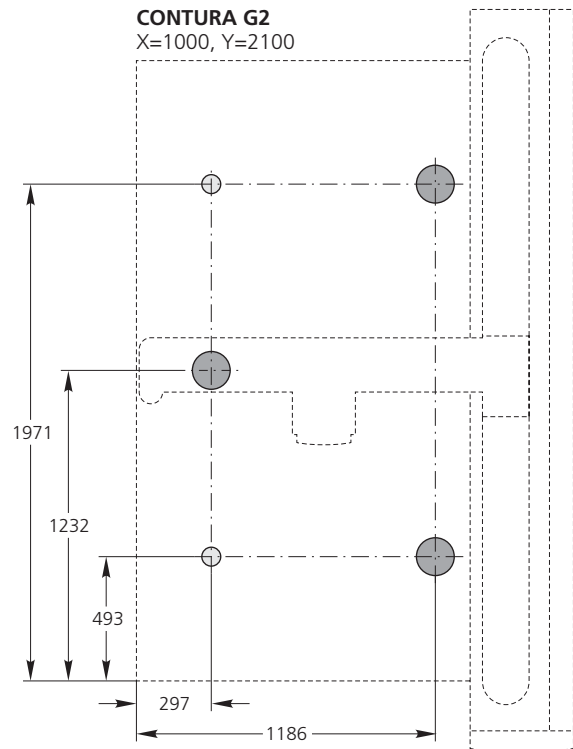
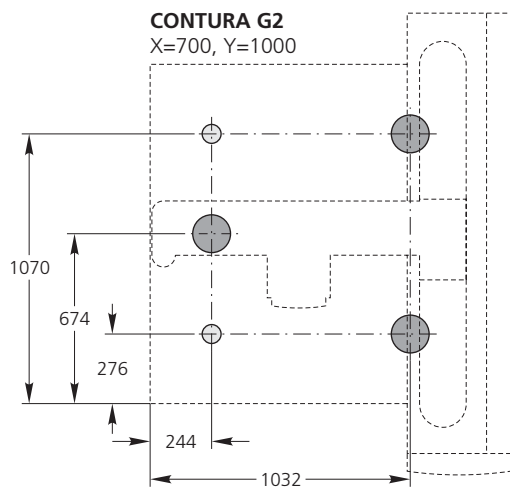
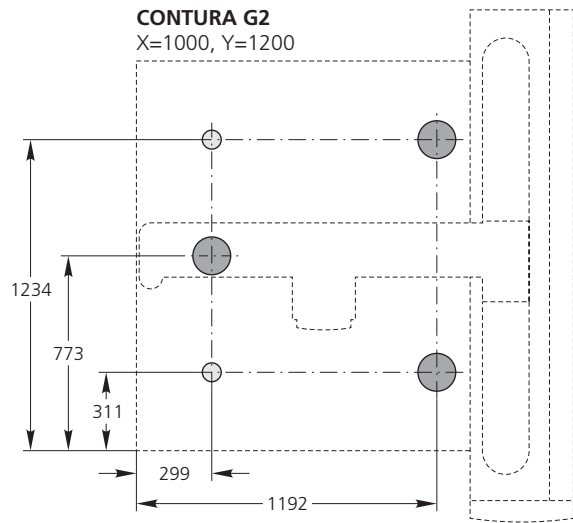
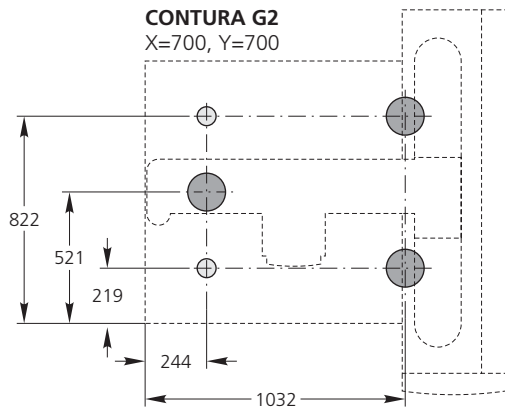

- **Support (A):** Cast iron plate $\varnothing 150$ (included in delivery)
- **Point of support** (tilt protection only)

Floor load on the supports (A)

CONTURA G2	
X=700, Y=700	38.5 N/cm ²
X=700, Y=1000	43.9 N/cm ²
CONTURA G2	
X=1000, Y=1200	67.8 N/cm ²
X=1000, Y=1600	85.5 N/cm ²
X=1000, Y=2100	157.9 N/cm ²
CONTURA G2 w. granite U-table (option)	
X=1000, Y=1200	73.0 N/cm ²
X=1000, Y=1600	91.9 N/cm ²
X=1000, Y=2100	165.7 N/cm ²



5. Dimensions of Granite Table and Fastening Hole Matrix

5.1 Measuring Table for Measuring Range of X=700, Y=700

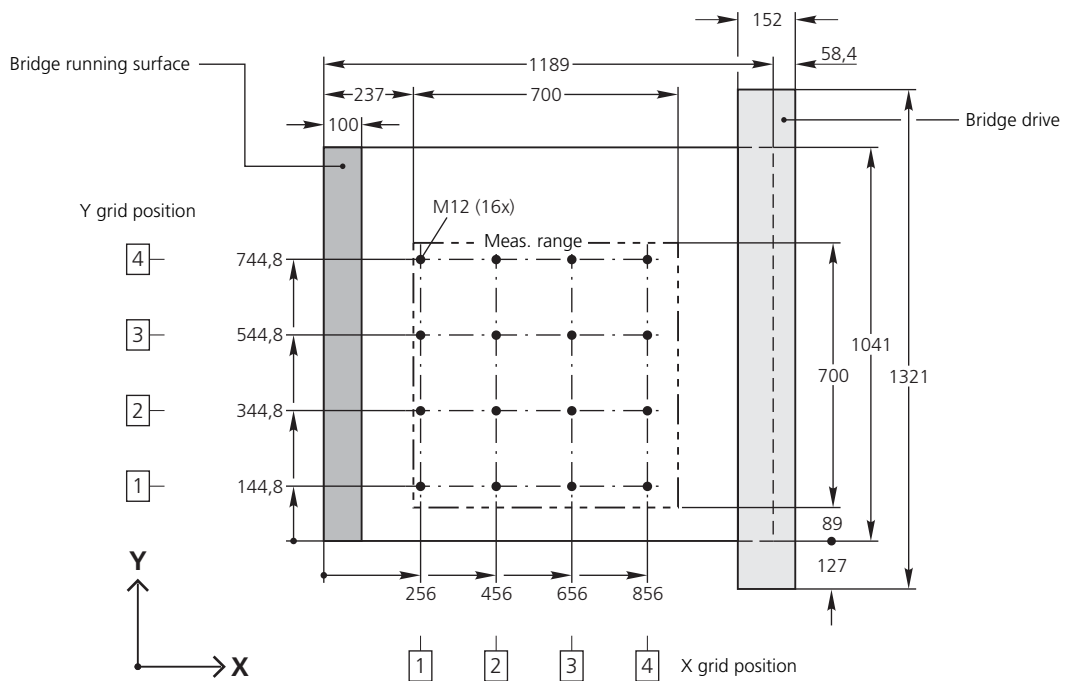

5.2 Measuring Table for Measuring Range of X=700, Y=1000

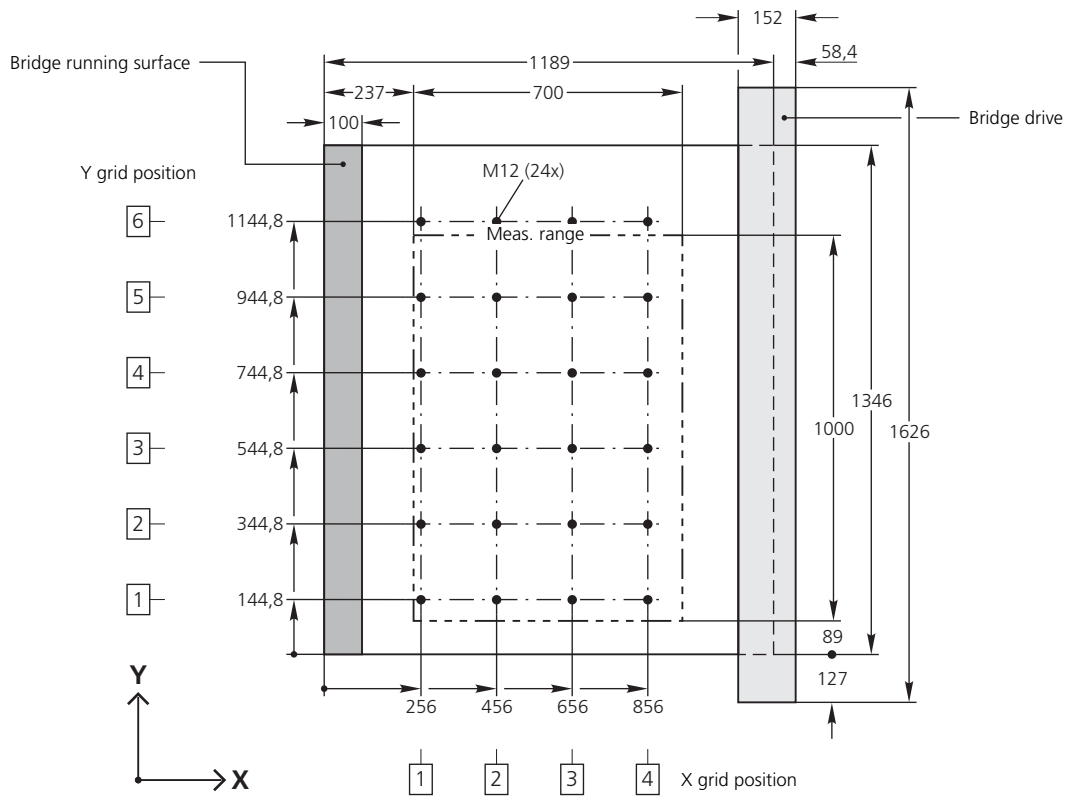

5.3 Measuring Table for Measuring Range of X=1000, Y=1200

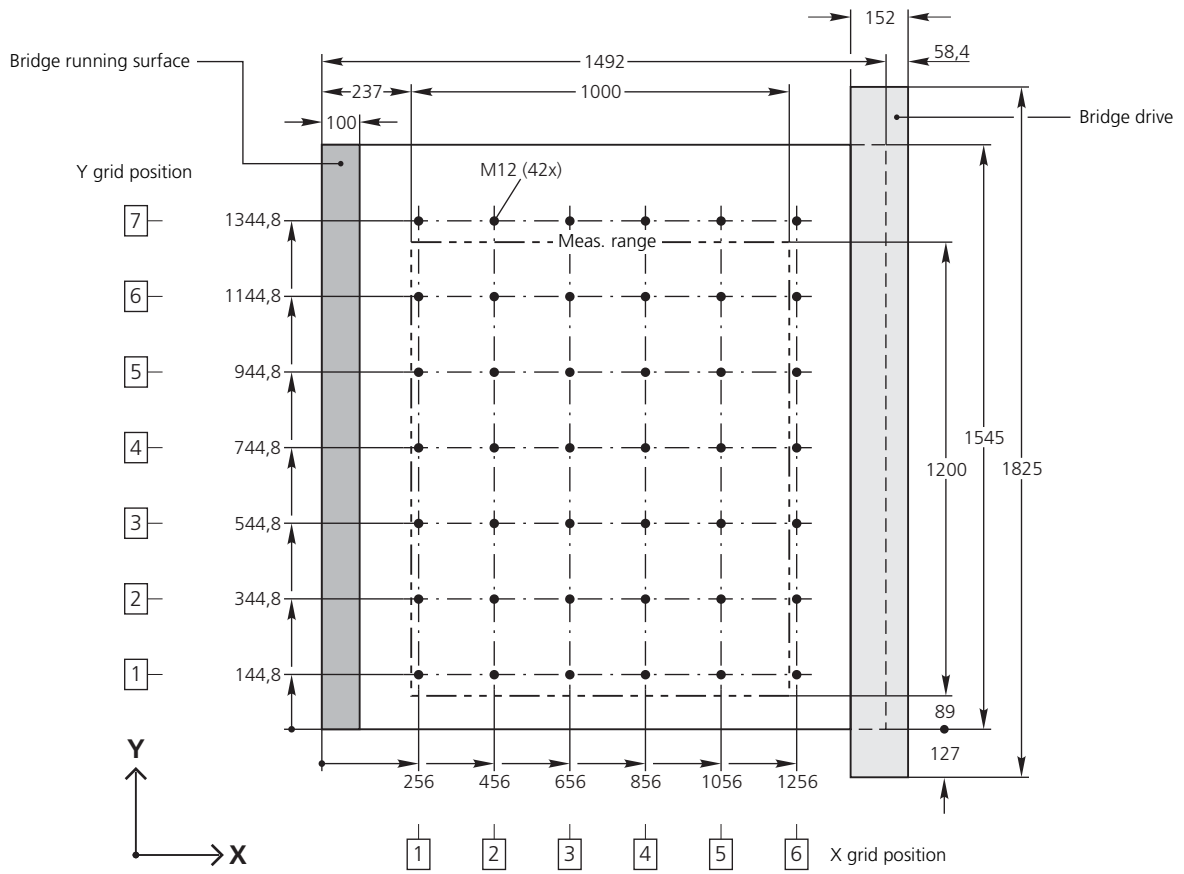

5.4 Measuring Table for Measuring Range of X=1000, Y=1600

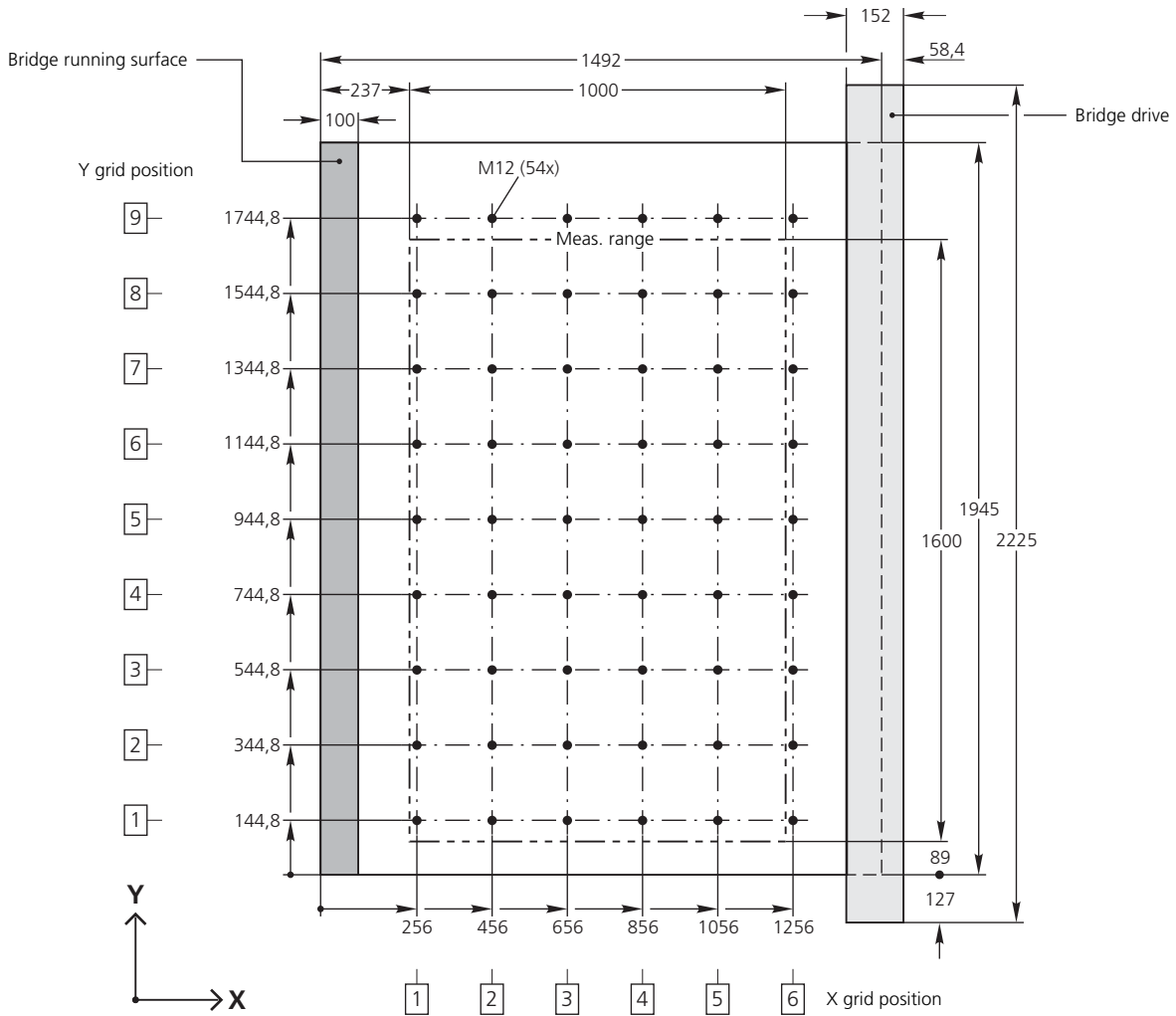

5.5 Measuring Table for Measuring Range of X=1000, Y=2100

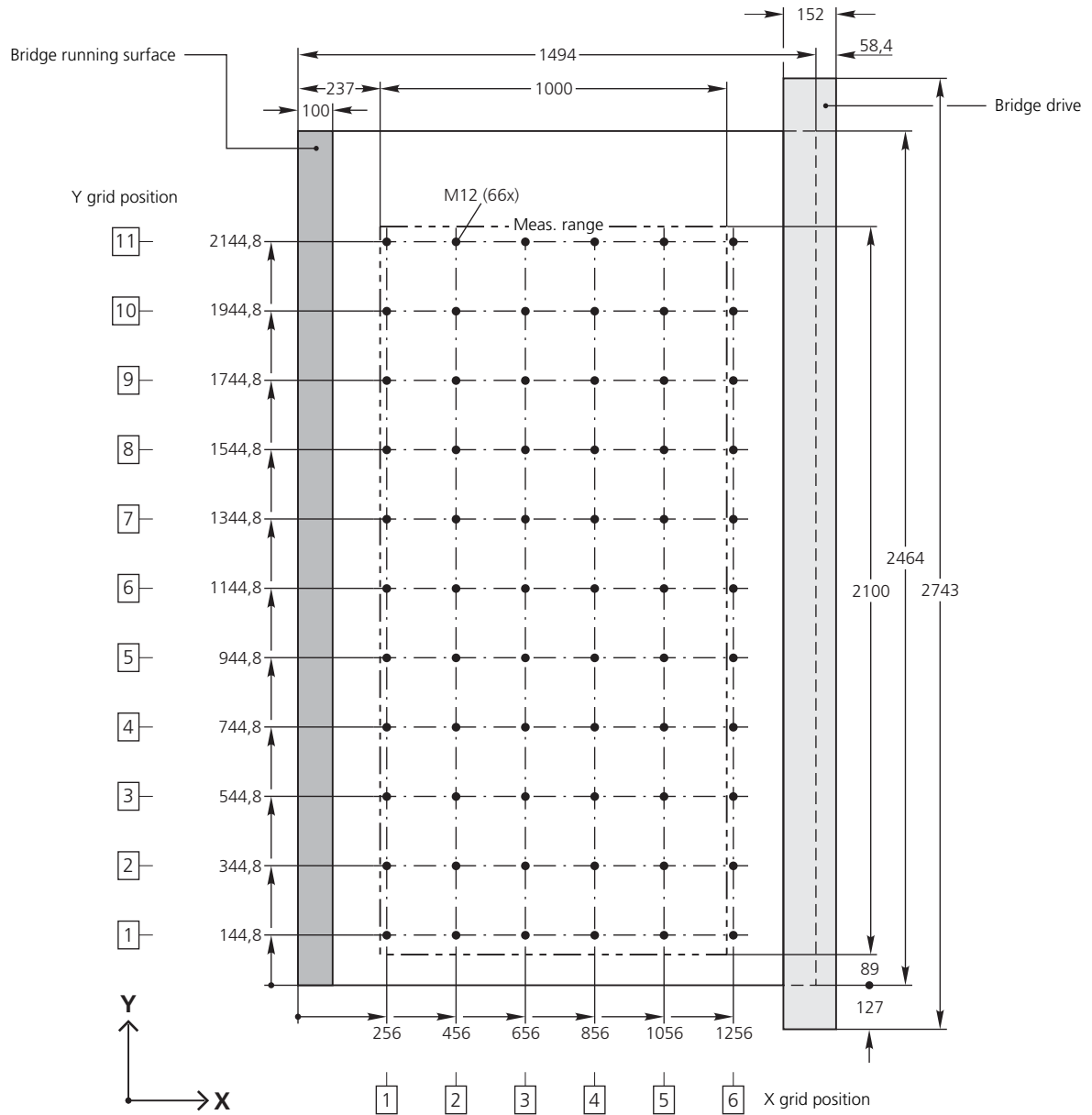

5.6 Measuring Table with U-Profile for Measuring Range of X=1000, Y=1200

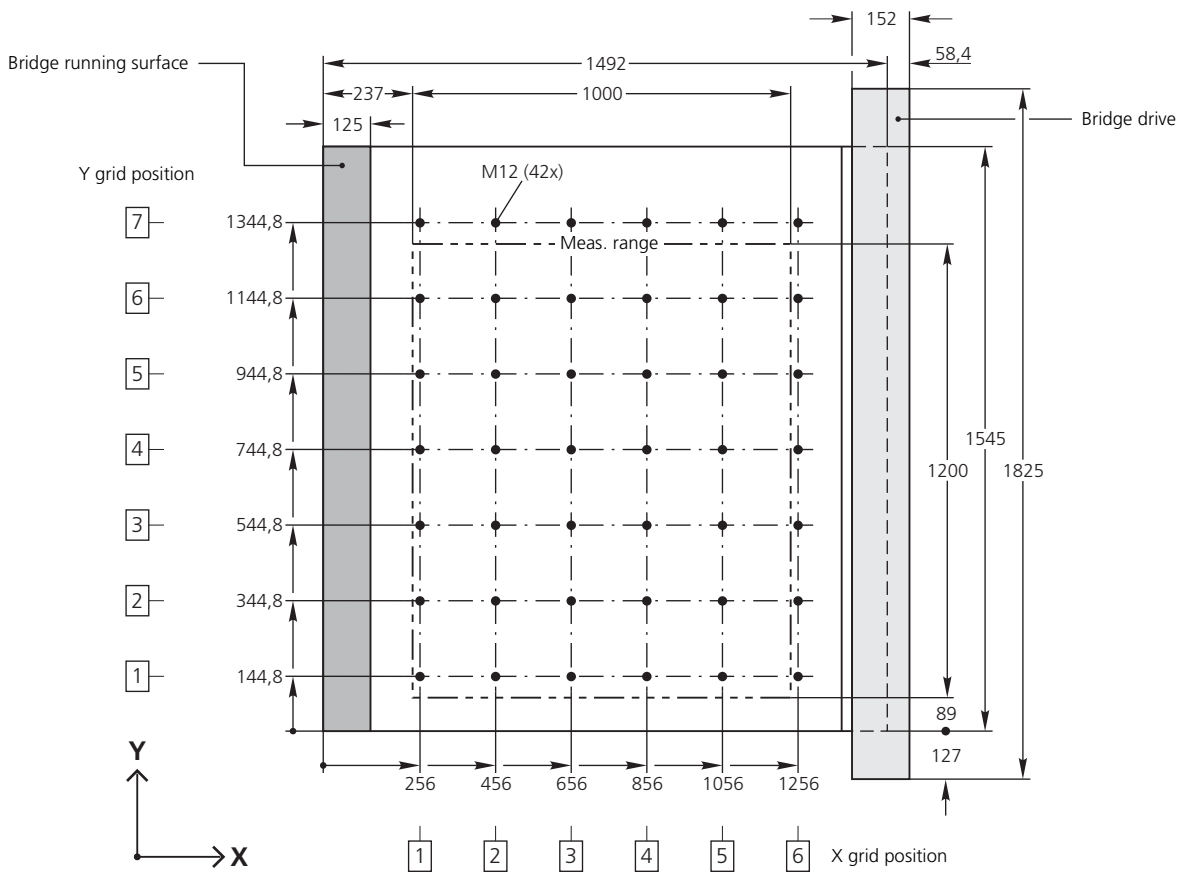

5.7 Measuring Table with U-Profile for Measuring Range of X=1000, Y=1600

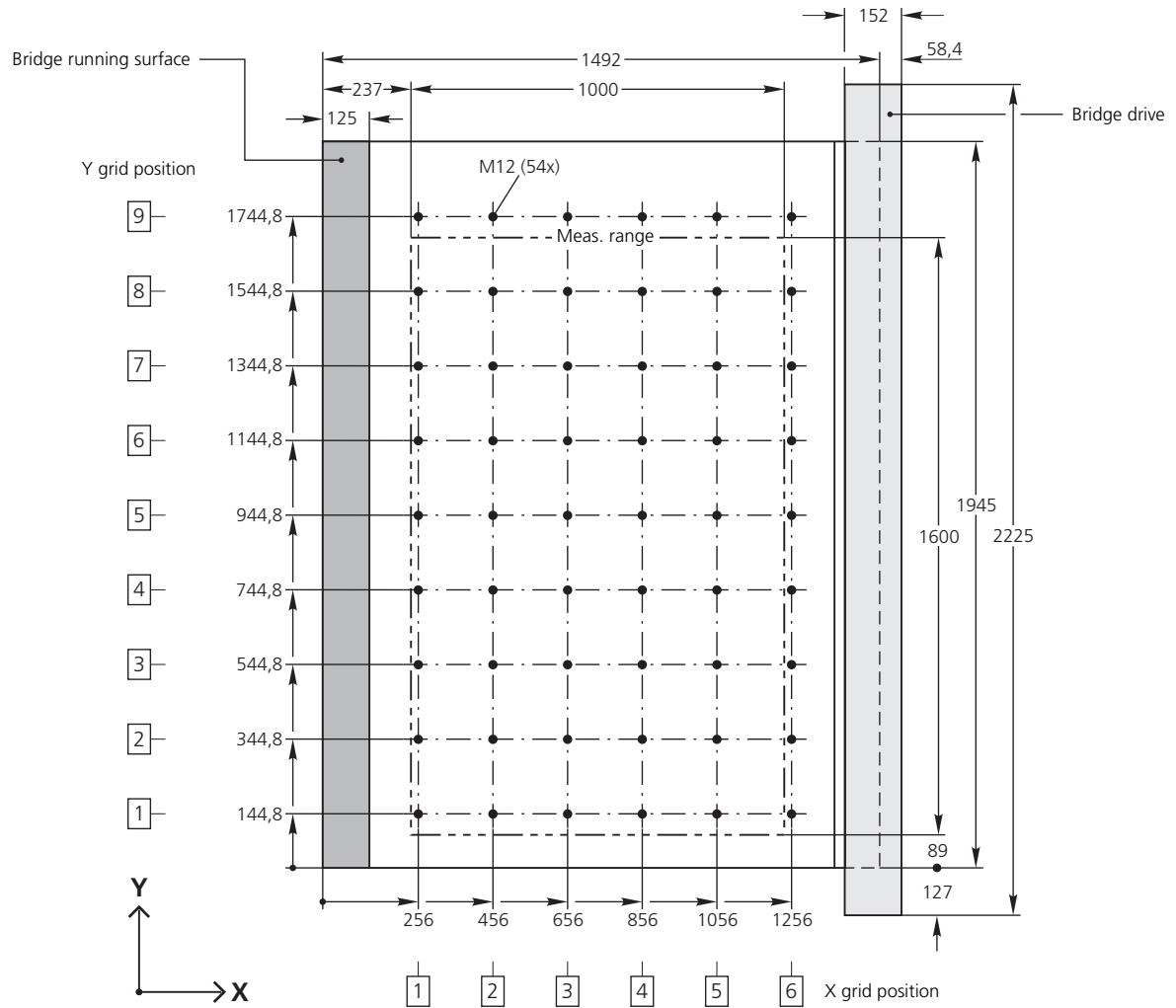

5.8 Measuring Table with U-Profile for Measuring Range of X=1000, Y=2100

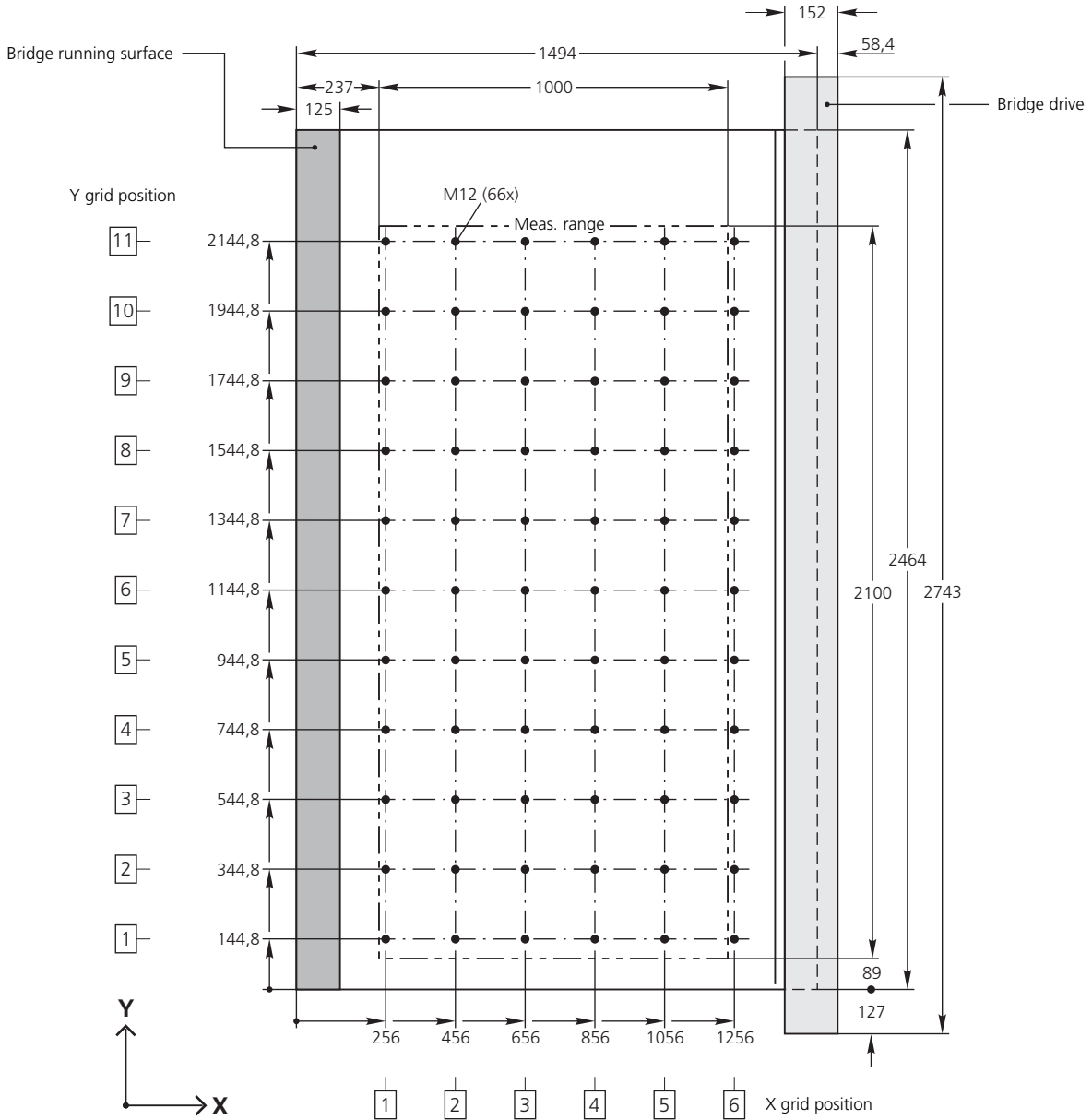

6. Cutout Patterns for Customer Floor Plan

6.1 Cutout Patterns for Contura G2

Scale: 1:30

CONTURA G2
X=700, Y=700

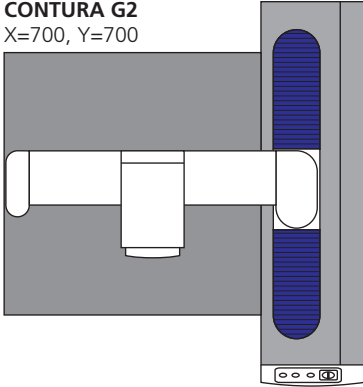

CONTURA G2
X=1000, Y=1200

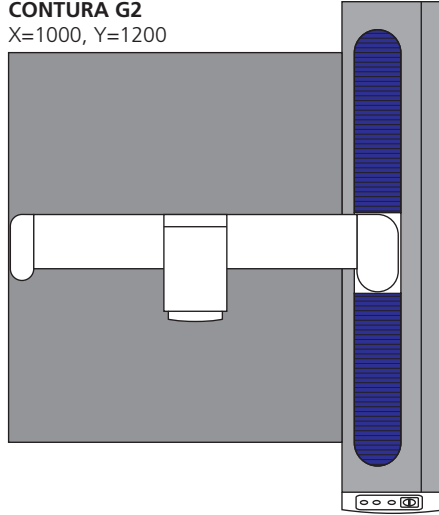

CONTURA G2
X=1000, Y=1600

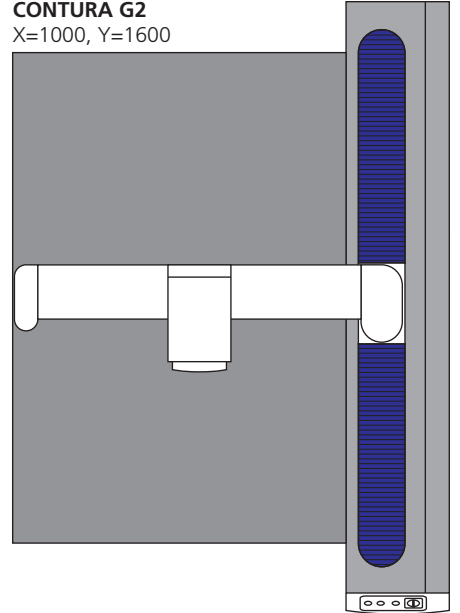

CONTURA G2
X=700, Y=1000

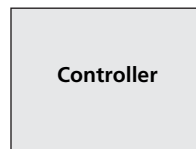
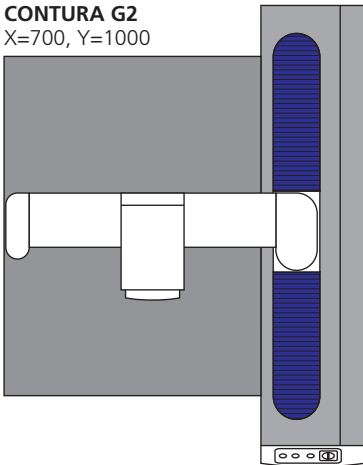

CONTURA G2
X=1000, Y=2100

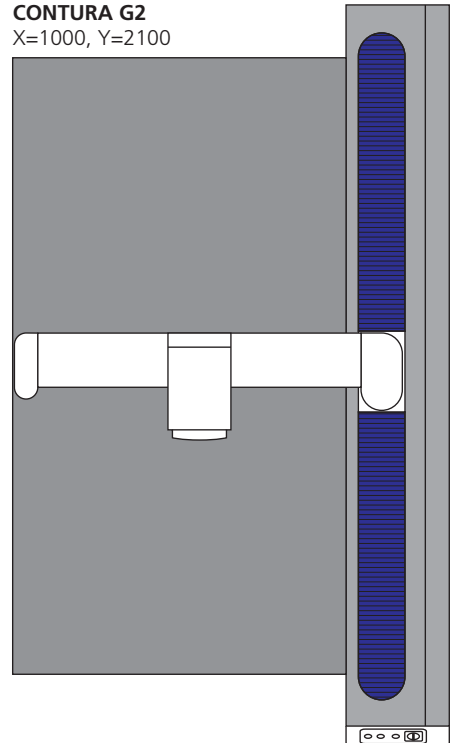

For editorial reasons, this page must remain empty.



6.2 Grid for Customer Space Assignment (Layout) Plan

Don't forget to take accessibility and min. distances into account! (scale: 1:30)

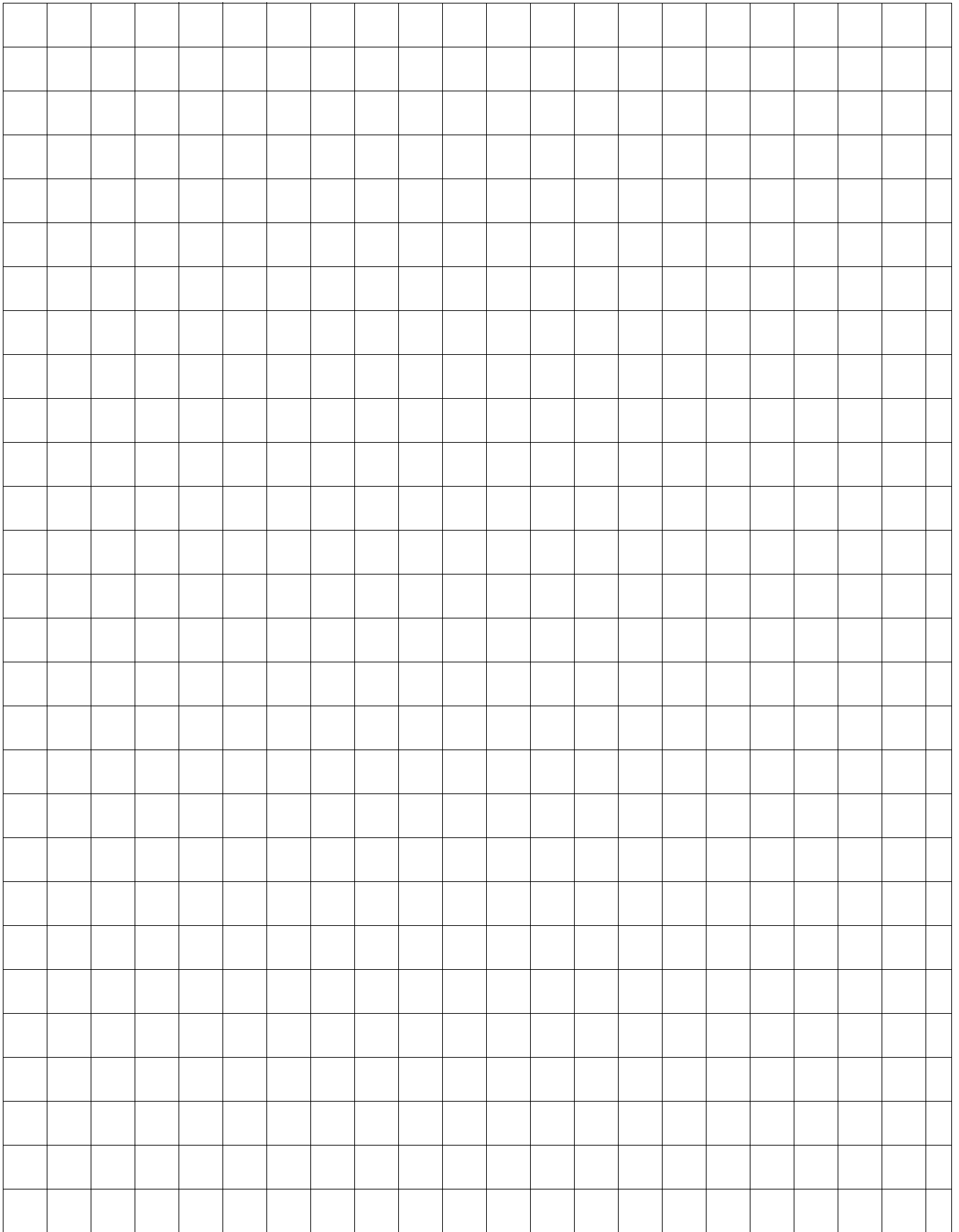

← 1 m →





